

design **9.2 x 10.8 x 21.2mm**
 9.2 x 15.8 x 16.2mm

dif. reflection sensors sensing range **2 to 60mm**

- ✓ selectable static or dynamic teach-in
- ✓ light-on or dark-on mode as necessary
- ✓ visible red light
- ✓ interference suppression



one of the “smallest” with adjustable background suppression

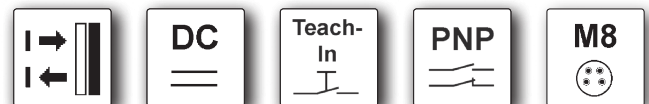

description

These *ipf sensors* are amongst the smallest optical devices in which the amplifier is already integrated. They have a repeat accuracy which is so precise, that they can be compared with laser sensors.

They work (almost) regardless of the color, background and surface of the objects which have to be recognized.

A (green) LED represents the receiving display. If the functional reserve is insufficient, due to soiling or an unfavorable alignment, the LED does not light up. This facilitates the alignment when being assembled and soiling is recognized before the device fails. The set switching function (normally closed/normally open) is signalized in combination with the yellow LED. For avoiding opposing optical influence the devices have a built-in interference suppression. This way, it is possible to mount sensor upon sensor (up to 4 units) without causing erroneous operations.

By means of a teach-button as well as a teach-input, the sensing range can be conveniently set, both on objects which are not moved (static), as well as objects which are moved (dynamic).

application examples

- ▶ detection of package units in stacking appliances
- ▶ using object materials which are not recognized by other proximity switches
- ▶ recognition of stacking heights on loading and unloading apparatus
- ▶ the sensor replaces proximity switches in applications which demand a longer sensing range
- ▶ position recognition on conveyor belts
- ▶ recognition of the smallest of objects
- ▶ installation, even in the case of very limited space

article-no.	OTQ90170	OTQ90175
version	diffuse reflection sensor, background suppression	diffuse reflection sensor, background suppression
operating distance	2 ... 60mm	2 ... 60mm
cable outlet	straight	angular

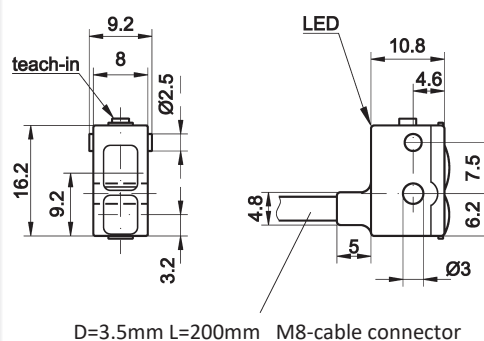
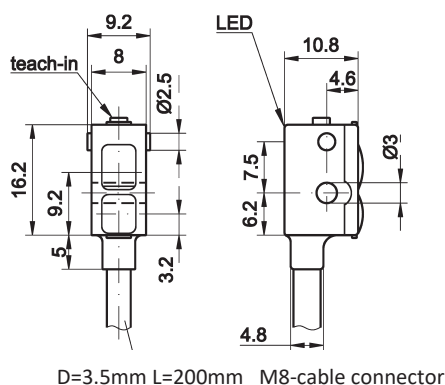

TECHNICAL DATA

sensing range	2 ... 60mm	2 ... 60mm
output signal	pnp, light-on/dark-on mode, no / nc	pnp, light-on/dark-on mode, no / nc
operating voltage	10 ... 30V DC	10 ... 30V DC
output current (max. load)	100mA	100mA
current consumption (w/o load)	≤ 25mA	≤ 25mA
voltage drop (max. load)	1.8V DC	1.8V DC
transmitting element (pulsed)	LED, red light	LED, red light
wavelength	660nm	660nm
response/decay time	≤ 0.5ms	≤ 0.5ms
sampling frequency	1kHz	1kHz
display (status)	yellow LED	yellow LED
display (functional reserve)	green flashing LED	green flashing LED
setting	teach-in	teach-in
short-circuit protection	+	+
reverse polarity protection	+	+
interference suppression	+	+
housing material	plastic	plastic
front screen material	PMMA	PMMA
design	9.2x10.8x21.2mm	9.2x15.8x16.2mm
operating temperature	-20 ... +50°C	-20 ... +50°C
system of protection (EN 60529)	IP65	IP65
connection	M8-cable connector, 200mm, PUR, 4-pin	M8-cable connector, 200mm, PUR, 4-pin
connection accessories	e.g. VK200375	e.g. VK200375
mounting accessories	AO000092	AO000092
mounting accessories (universal holder)	AO000116	AO000116

connection

connector device

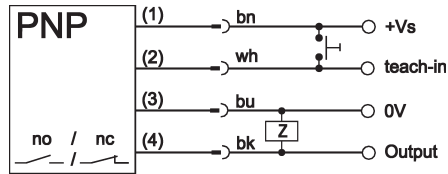

wire colors: bn = brown (1), wh = white (2), bu = blue (3), bk = black (4)

sensing range reduction

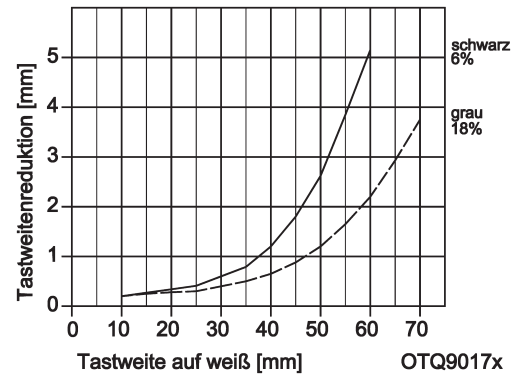

universal holder AY000116
consisting of base module ...

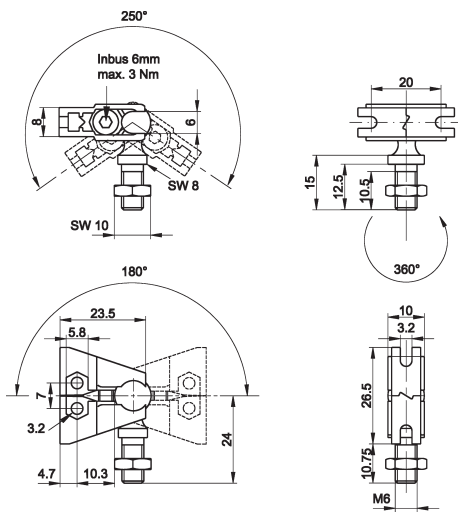

... and fitting panel

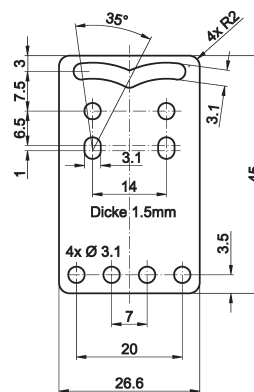

mounting profile AO000092

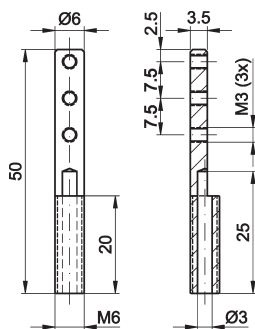

ACCESSORIES

article-no.	description	note
AY000088	base module *	jaw: stainless steel, ball pin: galvanized steel
AY000116	mounting kit for sensors	stainless steel
AO000092	holder, metal, mounting profile	nickel-plated brass

* The **AY000088** base module is contained in every mounting kit.
material of bolts and nuts: galvanized steel

This data sheet contains the standard versions only. Kindly request the availability of other output- and connection functions.

We will be pleased to supply the matching cable socket for your devices with connector. Please refer to the list in catalog chapter „accessories“ under „cable sockets **ipf-SENSORFLEX®**“ or search our website for „VK“.

Warning: Never use these devices in applications where the safety of a person depends on their functionality.

This data sheet as well as your personal contact can be found at www.ipf.de

NOTES

A large grid area for taking notes, consisting of a 20x30 grid of small squares.