

OE160470

OPTICAL SENSORS • THROUGH-BEAM SENSORS RECEIVERS

Optical sensors function contactlessly. They detect objects independent of their characteristics (e.g., shape, color, surface structure, material). The basic operating principle is based on the transmission and reception of light. There are three different versions: 1. The through-beam sensor consists of two separate devices, a transmitter and a receiver that are aligned with one another. If the light beam between the two devices is interrupted, the switching output integrated in the receiver changes its status. 2. With the retro-reflective sensor, the transmitter and receiver are located in one device. The emitted light beam is reflected back to the receiver by a reflector that is to be mounted opposite the device. As soon as the light beam is interrupted, the switching output integrated in the device changes its status. 3. With the diffuse reflection sensor, the transmitter and receiver are in one device. The emitted light beam is reflected by the object that is to be detected. As soon as the receiver detects the reflected light, the switching output integrated in the device changes its status.



MECHANICAL DATA

Ambient temperature (MAX)	65 °C
Ambient temperature (MIN)	-25 °C
Degree of protection (IP)	IP67
Housing design	Cuboid
Housing material	Zinc die-cast
Material of optical surface	PMMA
Sensor height	35 mm
Sensor length	35 mm
Sensor width	12.4 mm

ELECTRICAL DATA

Decay time	1 ms
Max. output current	100 mA
Measuring range	6 m
No-load current	17 mA
No-load current, receiver	17 mA
Number of pins	4
Operating voltage (MAX)	30 V
Operating voltage (MIN)	10 V
Rated switching distance	6000 mm
Response time	1 ms
Reverse polarity protection	Yes
Scanning function	Light-/dark-on mode
Short-circuit-proof	Yes
Switching frequency	500 Hz
Type of electrical connection	Connector M8
Type of input voltage	DC

ELECTRICAL DATA

Type of switching function	Anticoincidence
Type of switching output	PNP
Voltage drop	1.8 V
Voltage type	DC
With LED display	Yes
With LED display (functional reserve)	Yes
With LED display (signal)	Yes
With time function	No

OPTICAL DATA

Light beam form	Point
Light source	Polarity free red light
Wavelength of the sensor	660 nm

OTHER DATA

Scope of delivery of the one-way system	Receiver
---	----------

CONNECTION

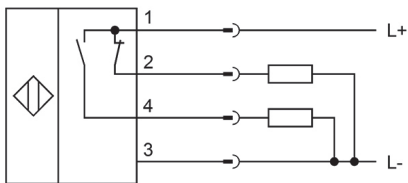

Colors: 1 = BN (brown), 2 = WH (white), 3 = BU (blue), 4 = BK (black)

Functions: 1 = L+, 2 = PNP NC, 3 = L-, 4 = PNP NO

DIMENSIONAL DRAWING

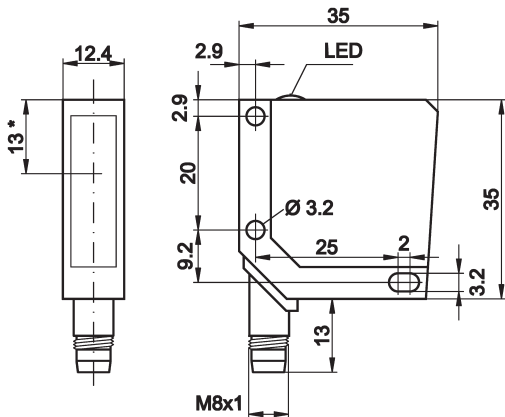

INSTALLATION



Mounting / Installation may only be carried out by a qualified electrician!

DISPOSAL



SAFETY WARNINGS

Before initial operation, please make sure to follow all safety instructions that may be provided in the product information!

Never use these devices in applications where the safety of a person depends on their functionality.