

dimensions	12.4 x 35 x 35mm	
through-beam sensors	operating range	7.5m
retro-reflective sensors	operating range	5m
dif. reflection sensors	sensing range	15 to 300mm

- ✓ dif. reflection sensors with background suppression
- ✓ retro-reflective sensors with polarizing filter
- ✓ simple adjustment
- ✓ high sensing ranges
- ✓ light-on and dark-on mode
- ✓ fast response time
- ✓ LED-display of the switch signal
- ✓ degree of protection IP67
- ✓ connection with M8-connector or cable

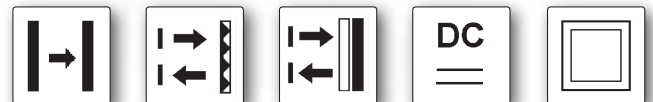

visible red light
robust metal housing



description

Optoelectronic sensors are indispensable components in all automated production processes. They are used in all applications where parts are to be detected, counted, measured or positioned in a way which does not involve contact and which is reliable and fast.

The devices feature a zinc diecast housing and are often used in connection with a PLC for automatic production processes and machines. For example, they detect objects made from metal, glass, plastic, wood and paper.

Functional monitoring of the sensor is possible for through-beam sensors using the test input in the transmitter. For this, the operating voltage potential is applied to the corresponding contact.

Although the distance of the diffuse reflection sensor devices can be set using a mechanical setting unit, the high degree of protection (IP67) is maintained. Objects are reliably recognized, regardless of their color. The functional principle behind these

sensing devices is based on triangulation principle, in which the position of the object is determined by the light reflected from it.

The sensors all work with visible red light and consequently, enable reliable and simple adjustment.

The yellow LED display lights up if the output is securely switched.

If, in the case of retro-reflective sensors, the yellow LED flashes when the output is switched, the respective device is working without sufficient functional reserve, e.g. through soiling or maladjustment.

application examples

- ▶ presence check of different objects
- ▶ collision avoidance in feeding motions
- ▶ control of object and stack heights
- ▶ limit switches, position switches and pulse generators

article-no.	OE160470	OS160070	OR160470
version	receiver	transmitter	retro-reflective sensor with polarizing filter
connection	M8-connector	M8-connector	M8-connector
operating range	6m	-	5m

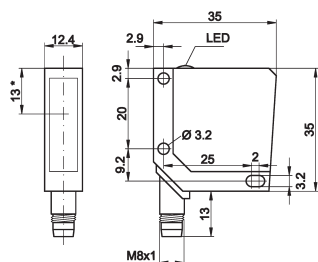

* receiver axis: 13mm

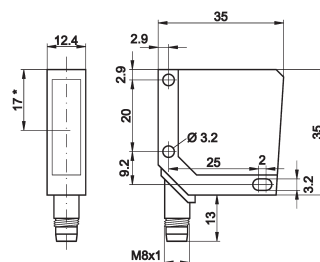

* transmitter axis: 17mm

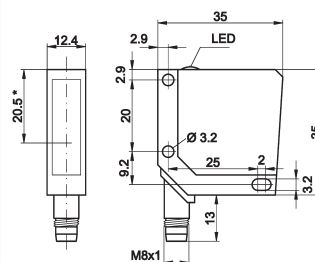

* transmitter axis: 20.5mm

TECHNICAL DATA

operating range	6m	-	5m
output signal	pnp, light-on/dark-on mode	-	pnp, light-on/dark-on mode
operating voltage	10 ... 30V DC	10 ... 30V DC	10 ... 30V DC
current consumption (w/o load)	≤ 17mA	≤ 30mA	≤ 35mA
output current (max. load)	100mA	-	100mA
voltage drop (max. load)	1.8V DC	-	1.8V DC
transmitting element (pulsed)	-	LED, red light	LED, red light
wavelength (transmitter)	-	660nm	660nm
sampling frequency	500Hz	-	500Hz
display (signal/functional reserve)	yellow LED / yellow flashing	-	yellow LED / yellow flashing
sensitivity adjustment	-	-	-
test input	-	operating volt. applied to contact 4	-
short-circuit protection	+	-	+
reverse polarity protection	+	+	+
dimensions	12.4x35x35mm	12.4x35x35mm	12.4x35x35mm
housing material	zinc diecast	zinc diecast	zinc diecast
front screen material	plastic PMMA	plastic PMMA	plastic PMMA
operating temperature	-25 ... +65°C	-25 ... +65°C	-25 ... +65°C
degree of protection (EN 60529)	IP67	IP67	IP67
connection	M8-connector, 4-pin	M8-connector, 4-pin	M8-connector, 4-pin
connection accessories	e.g. VK200371	e.g. VK200371	e.g. VK200371
mounting accessories (mounting bracket)	e.g. AO000067	e.g. AO000067	e.g. AO000067
mounting accessories (universal holder)	AY000118	AY000118	AY000118

article-no.	OT160400	OT160470
version	dif. reflection sensor with background suppression	dif. reflection sensor with background suppression
connection	cable	M8-connector
sensing range	15 ... 300mm	15 ... 300mm

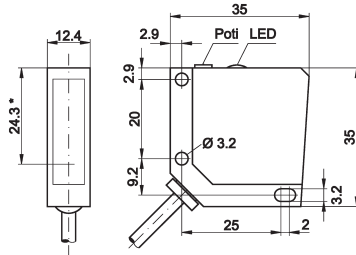

* transmitter axis: 24.3mm
24.3mm

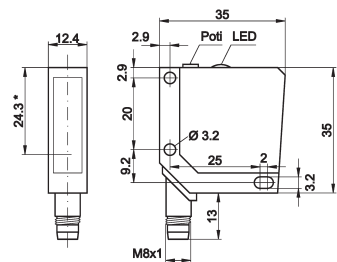

* transmitter axis:

TECHNICAL DATA

sensing range	15 ... 300mm	15 ... 300mm
output signal	pnp, light-on/dark-on mode	pnp, light-on/dark-on mode
operating voltage	10 ... 30V DC	10 ... 30V DC
current consumption (w/o load)	≤ 35mA	≤ 35mA
output current (max. load)	100mA	100mA
voltage drop (max. load)	1.8V DC	1.8V DC
transmitting element (pulsed)	LED, red light	LED, red light
wavelength (transmitter)	660nm	660nm
sampling frequency	500Hz	500Hz
display (signal/reserve)	yellow LED / -	yellow LED / -
sensitivity adjustment	mechanical, 5 revolutions	mechanical, 5 revolutions
interference suppression	+	+
short-circuit protection	+	+
reverse polarity protection	+	+
dimensions	12.5x35x35mm	12.5x35x35mm
housing material	zinc diecast	zinc diecast
front screen material	plastic PMMA	plastic PMMA
operating temperature	-25 ... +65°C	-25 ... +65°C
degree of protection (EN 60529)	IP67	IP67
connection	2m PVC cable, 4-wire	M8-connector, 4-pin
connection accessories	-	e.g. VK200371
mounting accessories (mounting bracket)	e.g. AO000067	e.g. AO000067
mounting accessories (universal holder)	AY000118	AY000118

connection

light-on and dark-on mode

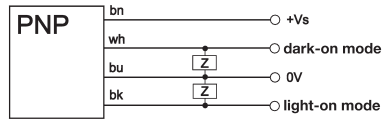

transmitter through-beam sensor

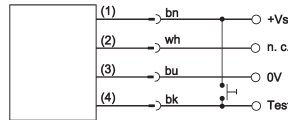

wire colors: bn = brown (1), wh = white (2), bu = blue (3), bk = black (4)

mounting bracket AO000067

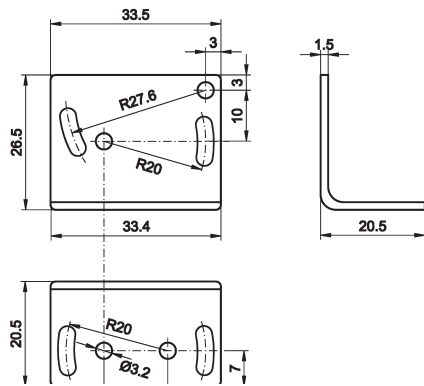

mounting accessories (universal holder) AY000118 consisting of base module

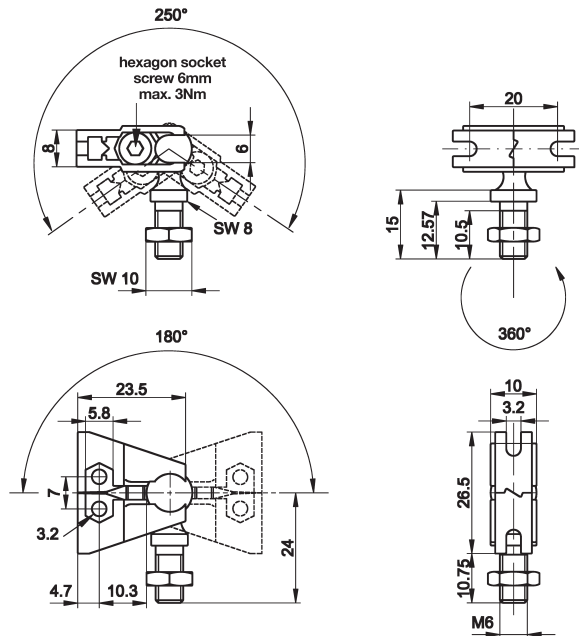

... and fitting panel

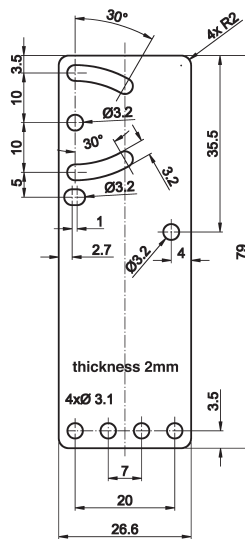

This data sheet contains the standard versions only. Kindly request the availability of other output- and connection functions.

We will be pleased to supply the matching cable socket for your devices with connector. Please refer to the list in catalog chapter „accessories“ under „cable sockets **ipf-SENSORFLEX**“ or search our website for „VK“.

Warning: Never use these devices in applications where the safety of a person depends on their functionality.