

dimensions	14.8 x 43 x 32.5mm	
retro-reflective sensor	range	10m
dif. reflection sensor	sensing range	20 to 350mm

- ✓ **robust plastic housing**
- ✓ **dif. reflection sensor with background suppression**
- ✓ **retro-reflective sensor with teach-in**
- ✓ **retro-reflective sensor laser class 1, diffuse reflection sensor laser class 2**
- ✓ **high switching frequency**
- ✓ **LED display for switching state and operating voltage**
- ✓ **dif. reflection sensor with exclusive-OR switching output**
- ✓ **high ambient light shielding**
- ✓ **connection with 4-pin M8-connector**

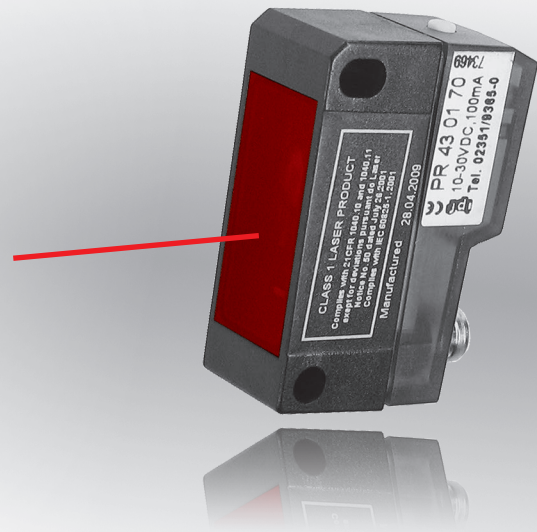

retro-reflective sensor with coaxial light beam diffuse reflection sensor with background suppression

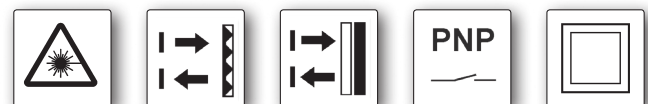

description

The retro-reflective sensor provides sensitivity adjustment via teach-in. This is possible both directly at the sensor and through the remote-teach input.

The distance setting of the diffuse reflection devices takes place via a mechanical setting unit. Degree of protection IP67 is retained and objects are recognized reliably, regardless of their color.

The functional principle behind these diffuse reflection sensors is based on the triangulation principle, in which the position of the object is determined by the angle of light reflected from it. It must be ensured with all triangulation sensors that the laser spot can be directly seen by the receiver lens and that there are no obstacles in front of the lens.

Through the special construction of the retro-reflective sensor lens, the transmitter and receiver beam is on the same axis. This „coaxial“ light beam makes it possible, for example, to

detect an object through a small opening, even when this is directly in front of the sensor.

The yellow LED display lights up if the output is securely switched. If the yellow LED flashes when the output is switched, the devices are working without sufficient functional reserve. This is the case for example, if the sensors are soiled or misadjusted. The green LED lights up after the operating voltage is applied. The sensors can always be aligned easily and reliably using the small, red laser spot.

application examples

- ▶ detection of object edges with high precision
- ▶ check of parts of any form and color
- ▶ contactless position recognition
- ▶ pulse generator for counting devices
- ▶ recognition of the smallest of objects

article-no.	PR430170	PT430470
version	retro-reflective sensor with polarizing filter coaxial light beam	diffuse reflection sensor with background suppression
output signal	pnp, dark-on mode	pnp, light-on/dark-on mode
operating range	10m	20 ... 350mm
article-no.	PR430270	-
version	retro-reflective sensor with polarizing filter coaxial light beam	-
output signal	pnp, light-on mode	-
operating range	10m	-

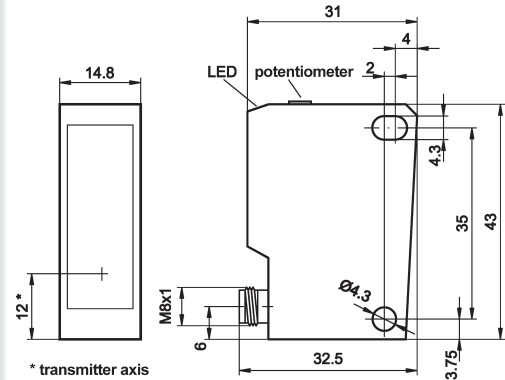
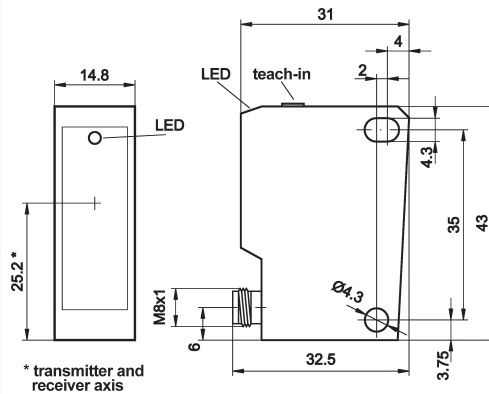

TECHNICAL DATA

range	10m	-
sensing range	-	20 ... 350mm
output signal	see above	pnp, light-on/dark-on mode
operating voltage	10 ... 30V DC	10 ... 30V DC
current consumption (w/o load)	≤ 35mA	≤ 35mA
output current (max. load)	100mA	100mA
voltage drop (max. load)	2.2V DC	2.2V DC
transmitting element	red laser diode	red laser diode
wavelength	650nm	650nm
laser focus distance	400mm	115mm
laser class	1	2
response/decay time	< 0.25ms	< 0.5ms
switching frequency	2kHz	1kHz
display (signal/reserve)	yellow LED / flashing	yellow LED / -
display (operation)	green LED	green LED
sensitivity adjustment	teach-in	mechanical, 9 revolutions
repeat accuracy	< 0.1mm at the laser focus distance	< 0.2mm at the laser focus distance
polarizing filter	+	-
short-circuit protection	+	+
reverse polarity protection	+	+
dimensions	43x14.8x32.5mm	43x14.8x32.5mm
housing material	plastic	plastic
front screen material	plastic	plastic
operating temperature	-10 ... +50°C	-10 ... +50°C
degree of protection (EN 60529)	IP67	IP67
connection	M8-connector, 4-pin	M8-connector, 4-pin
connection accessories	e.g. VK200375	e.g. VK200375
mounting accessories	AO000082	AO000082
mounting accessories (universal holder)	AY000120	AY000120
accessories	reflector AO000006	-

connection

PR430170

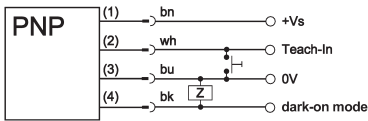

PR430270

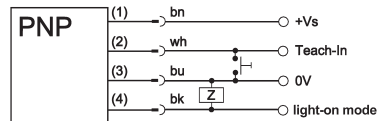

PT430470

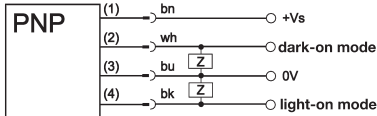

wire colors: bn = brown (1), wh = white (2), bu = blue (3), bk = black (4)

laser beam course

retro-reflective sensor

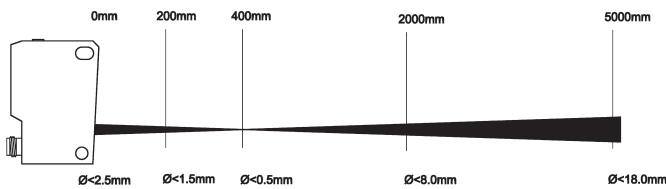

diffuse reflection sensor

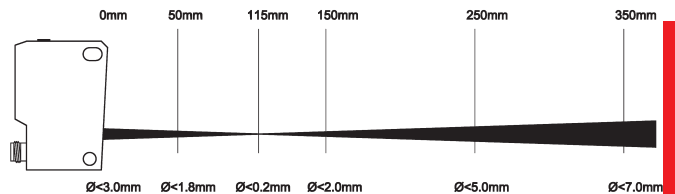

Warning

PR430170 and PR430270

laser class 1
according to DIN EN 60825-1

PT430470

Caution! Laser Radiation!
Do not stare into the beam!

laser class 2
according to DIN EN 60825-1
wavelength 630 ... 680nm
max. output power 1mW

universal mounting AY000120

consisting of base module ...

... and fitting panel

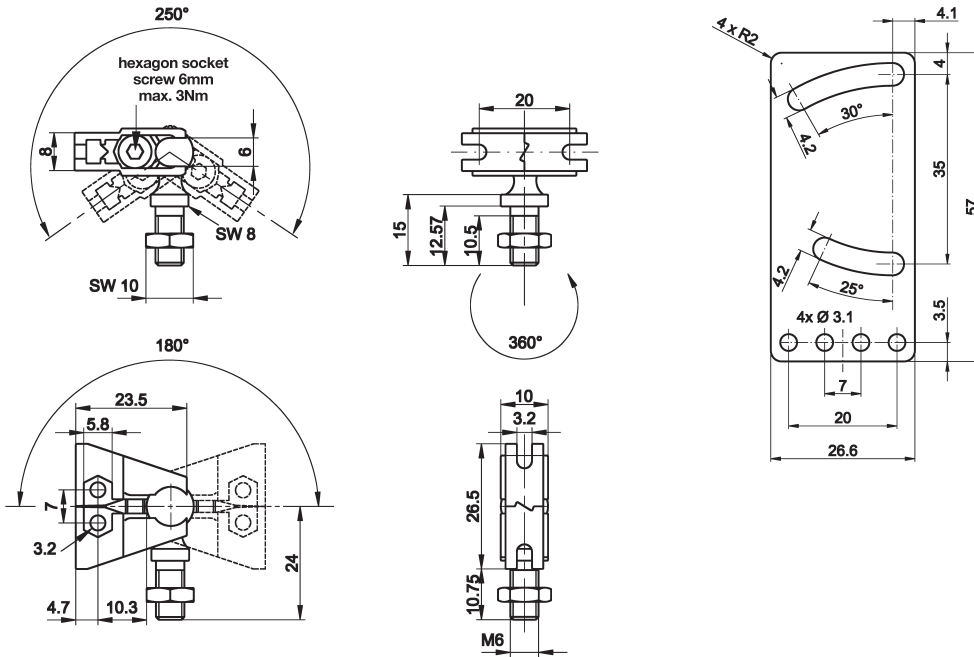

mounting bracket AO000082

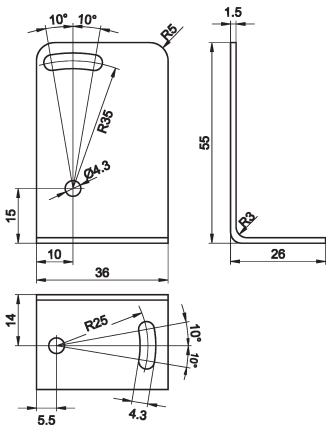

ACCESSORIES

article-no.	description	note
AY000088	base module *	flanges: stainless steel, ball pins: galvanized steel
AY000120	mounting kit for Px43 sensors	stainless steel
AO000082	bracket	aluminum

* The **AY000088** base module is contained in every mounting kit.

Material of bolts and nuts: galvanized steel

This data sheet contains the standard versions only. Kindly request the availability of other output and connection versions.

We will be pleased to supply the matching cable socket for your devices with connector. Please refer to the list in catalog chapter „accessories“ under „cable sockets **ipf**-SENSORFLEX®“ or search our website for „VK“.

Warning: Never use these devices in applications where the safety of a person depends on their functionality.

This data sheet as well as your personal contact can be found at www.ipf-electronic.com