

dimensions	M8x1 M12x1 M18x1 M30x1.5	
flush	switching distance	2 ... 10mm

- ✓ all-stainless steel housing
- ✓ high pressure resistance up to max. 100bar
- ✓ high switching distances on steel, brass and aluminum
- ✓ outstanding impermeability
- ✓ LED display for assured switching range
- ✓ high switching frequency up to 5kHz

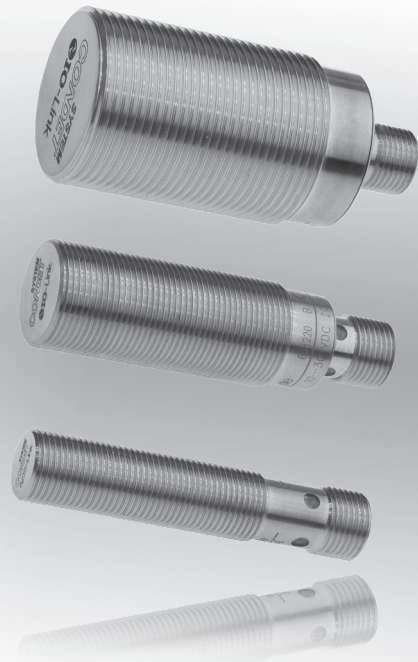

**active surface made from metal  
IO-Link-capable devices**



**description**

IO-Link is a globally standardized IO technology (IEC 61131-9) for communicating with sensors as well as actuators. The powerful point-to-point communication is based on the well-established three-conductor sensor and actuator connection. It allows additional information, e.g., damping, sensor failure or switching frequency as well as the setting of sensor parameters such as switching performance, timer functions, etc., to be communicated without any additional requirements on the cable material. The series features particularly large switching distances. Thanks to special technology these high switching distances can be achieved not only on steel but also on other metals such as aluminum or brass.

A further important characteristic of these sensors is their all-stainless steel housing. This means that the active surface of the devices is sealed against liquids and gases, to which the housing material is resistant. The devices offer a high pressure resistance thanks to the comparatively thick gauge material of the active surface. The pressure resistance of the devices refers to the active surface and the thread only. In addition they are much more resistant to mechanical loads than usual proximity switches.

Attention should be paid to the size of the object (standard

target) and the surface condition (even surface) to guarantee the maximum switching distance.

The LED status display lights up permanently if the distance between the sensor surface and the object is not more than 80% of the indicated switching distance. The object is reliably detected.

In the case of larger distances, (80 to 100% of the indicated switching distance) the LED display flashes.

correction factors indicate the change relating to the switching distance if materials other than St37 (steel) are used. The change in the switching distance depends on the type, characteristics (internal structure), size and the geometry of the material that is to be detected. In order to assess the approximate switching distance on the materials which differ from St37, the value for St37 has to be multiplied by the appropriate correction factor.

**application examples**

- ▶ operation in an extreme environment (oil, dirt, pressure)
- ▶ use where a high demand is made in terms of reliability and longevity

article-no.	IC080172	IC120122	IC180122	IC300122
switching distance	2mm	3mm	5mm	10mm
output	PNP, NO	PNP, NO	PNP, NO	PNP, NO
connection	M8-connector	M12-connector	M12-connector	M12-connector

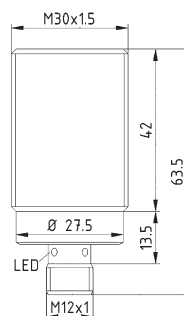
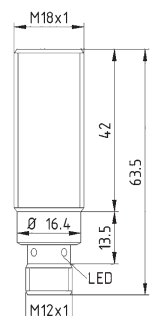
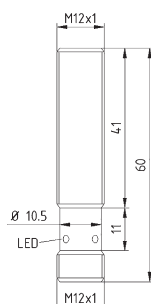
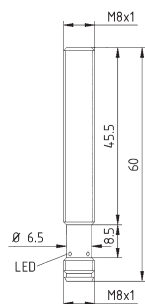

### TECHNICAL DATA

switching distance (S <sub>n</sub> )	2mm	3mm	5mm	10mm
IO-Link (IEC 61131-9)	+	+	+	+
pressure resistance	100bar	80bar	60bar	40bar
output signal	PNP, NO	PNP, NO	PNP, NO	PNP, NO
operating voltage	10 ... 30V DC	10 ... 30V DC	10 ... 30V DC	10 ... 30V DC
current consumption (w/o load)	≤ 10mA	≤ 10mA	≤ 10mA	≤ 10mA
output current (max. load)	200mA	200mA	200mA	200mA
voltage drop (max. load)	2.0V DC	2.0V DC	2.0V DC	2.0V DC
norm measuring plate	8x8x1mm, FE360	12x12x1mm, FE360	18x18x1mm, FE360	30x30x1mm, FE360
hysteresis	≤ 20%	≤ 15%	≤ 15%	≤ 15%
repeat accuracy *	≤ 0.1mm	≤ 0.2mm	≤ 0.3mm	≤ 0.3mm
readiness delay	30ms	25ms	25ms	50ms
correction factors (St37/Alu/Ms)	1.0 / 1.0 / 1.4	1.0 / 1.0 / 1.4	1.0 / 1.0 / 1.3	1.0 / 1.0 / 1.3
correction factors (stainl. steel/Cu)	- / 0.8	- / 0.9	- / 0.8	- / 0.8
correction factors (V2A: 1mm/2mm)	0.2 / 0.4	0.2 / 0.6	0.3 / 0.7	0.4 / 0.6
switching frequency	100Hz	100Hz	100Hz	50Hz
display (signal)	yellow LED	yellow LED	yellow LED	yellow LED
display (functional reserve)	yellow LED, flashing	yellow LED, flashing	yellow LED, flashing	yellow LED, flashing
short-circuit protection	+	+	+	+
reverse polarity protection	+	+	+	+
dimensions	M8x1	M12x1	M18x1	M30x1.5
length (thread/complete)	45.5mm / 60mm	41mm / 60mm	42mm / 63.5mm	42mm / 63.5mm
housing material	V2A (1.4305)	V2A (1.4305)	V2A (1.4305)	V2A (1.4305)
material (active surface)	V2A (1,4305)	V2A (1,4305)	V2A (1,4305)	V2A (1,4305)
material thickness (active surface)	0.25mm	0.4mm	0.6mm	1.0mm
operating temperature	-25 ... +70°C	-25 ... +70°C	-25 ... +70°C	-25 ... +70°C
degree of protection (EN 60529)	IP67	IP67	P67	IP67
connection	M8-connector, 3-pin	M12-connector, 3-pin	M12-connector, 3-pin	M12-connector, 3-pin
connection accessories	e.g. <b>VK200075</b>	e.g. <b>VK200025</b>	e.g. <b>VK200025</b>	e.g. <b>VK200025</b>
mounting accessories (clip)	e.g. <b>AY000047</b>	e.g. <b>AY000049</b>	e.g. <b>AY000051</b>	e.g. <b>AY000061</b>
mounting accessories (universal holder)	<b>AY000115</b>	<b>AY000115</b>	<b>AY000117</b>	-

\* at 20 ... 30V DC and 18 ... 28°C

**connection**

**connector devices**

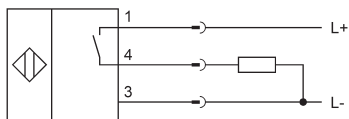

1 = L+, 3 = L-, 4 = PNP NO

**wire color:** 1 = BN (brown), 3 = BU (blue), 4 = BK (black)

**mounting parameters**

**flush mounting**

**M8**

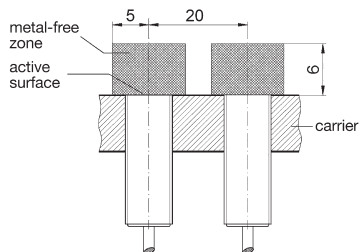

**correction factors when mounting into carrier**

carrier	factor
aluminum	0.9
steel	0.9
brass	0.9
stainless steel	0.9

**M12**

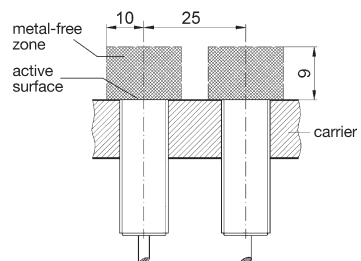

carrier	factor
aluminum	0.9
steel	0.9
brass	0.9
stainless steel	0.9

**M18**

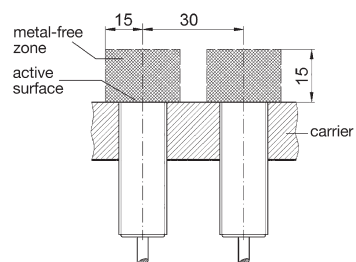

carrier	factor
aluminum	0.9
steel	0.9
brass	0.9
stainless steel	0.9

**M30**

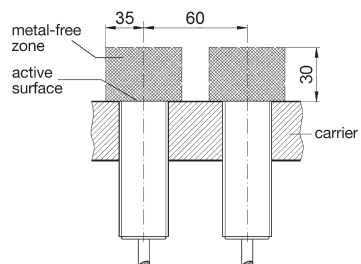

carrier	factor
aluminum	0.8
steel	0.9
brass	0.8
stainless steel	0.9

mounting accessories (universal holder) AY000115, AY000117

consisting of base module

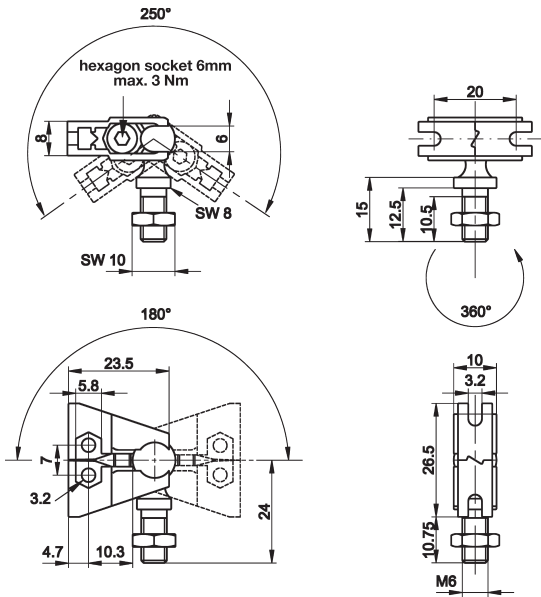

... and fitting panel

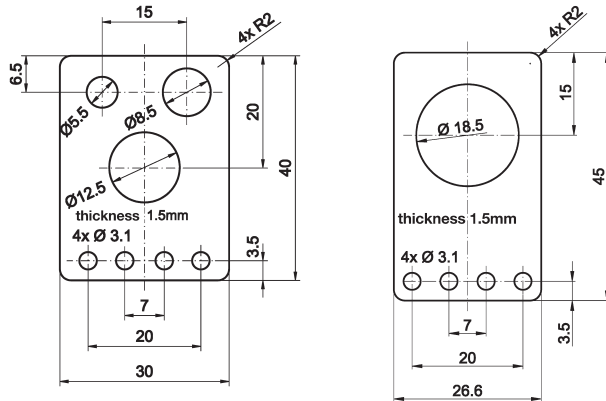

## ACCESSORIES

article-no.	description	note
AY000088	base module*	jaw: stainless steel, ball pin: galvanized steel
AY000115	mounting kit for M5, M8, M12 sensors	stainless steel
AY000117	mounting kit for M18 sensors	stainless steel

\* The AY000088 base module is contained in every mounting kit.

Material of bolts and nuts: galvanized steel

The IODD files necessary for the IO-Link functionality can be downloaded from our homepage upon entry of the article number.

This data sheet only contains the available standard variants. For other output / connection variants, we kindly ask that you contact us.

We are happy to supply the right cable socket for the plug equipment. You will find a list in the "accessories" section of the catalog under **ipf-SENSORFLEX**® "cable sockets" or in the search window on our homepage [www.ipf-electronic.com](http://www.ipf-electronic.com) (using the search term "VK").

**Warning:** Never use these devices in applications where the safety of a person depends on their functionality.

This data sheet as well as your personal contact can be found at [www.ipf-electronic.com](http://www.ipf-electronic.com)