

## OT370505

### OPTICAL SENSORS • DIFFUSE REFLECTION SENSORS WITH BACKGROUND SUPPRESSION

Optical sensors function contactlessly. They detect objects independent of their characteristics (e.g., shape, color, surface structure, material). The basic operating principle is based on the transmission and reception of light. There are three different versions: 1. The through-beam sensor consists of two separate devices, a transmitter and a receiver that are aligned with one another. If the light beam between the two devices is interrupted, the switching output integrated in the receiver changes its status. 2. With the retro-reflective sensor, the transmitter and receiver are located in one device. The emitted light beam is reflected back to the receiver by a reflector that is to be mounted opposite the device. As soon as the light beam is interrupted, the switching output integrated in the device changes its status. 3. With the diffuse reflection sensor, the transmitter and receiver are in one device. The emitted light beam is reflected by the object that is to be detected. As soon as the receiver detects the reflected light, the switching output integrated in the device changes its status.



#### MECHANICAL FEATURES

Ambient temperature	-30 °C ... 70 °C
Cable length	5 m
Degree of protection (IP)	IP67 / IP69k
Housing design	Cuboid
Housing material	Stainless steel 1.4404
Increased ambient temperatures >70°C	+
Material of optical surface	PMMA
Number of cores	4
Reflector included in the scope of delivery	-
Sensor height	35.5 mm
Sensor length	25 mm
Sensor width	14 mm
Storage temperature	70 °C
Storage temperature	-30 °C

#### ELECTRICAL FEATURES

Adjustment range	20 mm ... 100 mm
Analog output 0 mA ... 20 mA	-
Analog output 0 V ... 10 V	-
Analog output -10 V ... +10 V	-
Analog output 4 mA ... 20 mA	-
Decay time	0.5 ms
Max. output current	100 mA
Max. switching distance	100 mm
No-load current	15 mA
Number of switching outputs	2
Operating voltage	10 V ... 30 V
Rated switching distance	100 mm
Readiness delay	300 ms
Residual ripple	15 %
Response time	0.5 ms
Scanning function	Light-/dark-on mode
Sensing range	20 mm ... 100 mm

**ELECTRICAL FEATURES**

Setting procedure	Manual adjustment
Short-circuit protection	+
Switching frequency	1000 Hz
Type of electrical connection	Cable
Type of switching function	Push-pull
Type of switching output	PNP/NPN
Voltage drop	2 V
Voltage type	DC
With LED display	+
With LED display (operation)	+
With LED display (signal)	+
With other analog output	-
With time function	-

**OPTICAL FEATURES**

Light source	Polarity free red light
Light spot	120 mm <sup>2</sup>
Wavelength of the sensor	620 nm
Triangulation	Background suppression
Light beam form	Line
Background suppression	+

**Other**

Packaging dimensions	124.0mm x 28.0mm x 149.0mm
Shipping weight	0.2kg
Tariff code	85365019

**Classification**

ipf product group	100
eClass 8.0	27270904
eClass 9.0	27270904
eClass 9.1	27270904
ETIM-5.0	EC002719
ETIM-6.0	EC002719
ETIM-7.0	EC002719

**Connection**

## Dimensional drawing

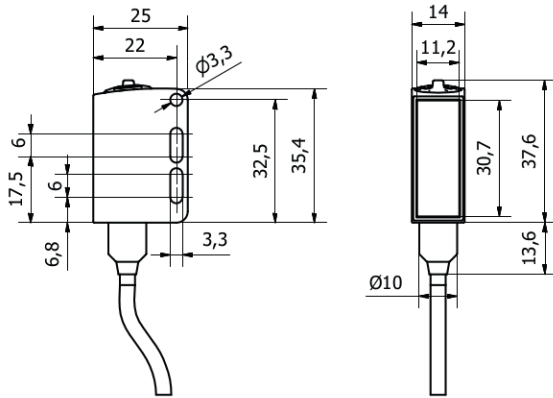

### Installation



Mounting / installation may only be carried out by a qualified electrician!

### Disposal



### Software

Please download the software or driver required for operating your new device on our homepage: [www.ipf.de](http://www.ipf.de)

### Safety warnings

Before initial operation, please make sure to follow all safety instructions that may be provided in the product information.

Never use these devices in applications where the safety of a person depends on their functionality.

LED lighting systems can generate intensive UV radiation, which can damage your eyes in case of improper use. The manufacturer cannot be held responsible for damages that result from improper use or connection.