

PE750146

LASER SENSORS • LINE SENSORS RECEIVERS

Optical sensors function contactlessly. They detect objects independent of their characteristics (e.g., shape, color, surface structure, material). The basic operating principle is based on the transmission and reception of light. There are three different versions: 1. The through-beam sensor consists of two separate devices, a transmitter and a receiver that are aligned with one another. If the light beam between the two devices is interrupted, the switching output integrated in the receiver changes its status. 2. With the retro-reflective sensor, the transmitter and receiver are located in one device. The emitted light beam is reflected back to the receiver by a reflector that is to be mounted opposite the device. As soon as the light beam is interrupted, the switching output integrated in the device changes its status. 3. With the diffuse reflection sensor, the transmitter and receiver are in one device. The emitted light beam is reflected by the object that is to be detected. As soon as the receiver detects the reflected light, the switching output integrated in the device changes its status.



MECHANICAL FEATURES

	3
Ambient temperature	-10 °C ... 50 °C
Degree of protection (IP)	IP54
Field height	73 mm
Housing coating	Anodized
Housing design	Cuboid
Housing material	Aluminum
Reflector included in the scope of delivery	-
Sensor height	20 mm
Sensor length	75 mm
Sensor width	118 mm
Storage temperature	85 °C
Storage temperature	-20 °C
Version	IV001916

ELECTRICAL FEATURES

Analog output 0 V ... 10 V	+
Analog output 4 mA ... 20 mA	+
Connection to amplifier	-
Input (TeachIn)	+
Laser power	0.4 mW
Max. output current	100 mA
Measurement frequency	1500 Hz
Measuring range	2 m
No-load current	200 mA
Number of pins	8
Number of pins of the communication interface	4
Number of pins of the communication interface, transmitter + receiver	4
Operating voltage	21.6 V ... 26.4 V
Rated switching distance	2000 mm
Relative repeat accuracy	8 µm
Residual ripple	10 %
Scanning function	Light-/dark-on mode

ELECTRICAL FEATURES

Setting procedure	Parameterization
Suitable for safety functions	-
Switching frequency	1500 Hz
Type of analog output	0 V ... 10 V / 4 mA ... 20 mA
Type of communication interface	Connector M5
Type of communication interface, transmitter + receiver	Connector M9
Type of electrical connection	Connector M9
Type of input voltage	DC
Type of plug-in contact, communication interface	Female (socket)
Type of plug-in contact, communication interface	Female (socket)
Type of switching function	Push-pull
Type of switching output	PNP/NPN
Voltage type	DC
With communication interface, RS-232	+
With LED display	+
With LED display (operation)	+
With LED display (signal)	+
With time function	-

OPTICAL FEATURES

Light source	Laser diode, red light
Wavelength of the sensor	670 nm
Resolution	8 µm
Light beam form	Line
Filter	Interference filter
Line sensor	+

OTHER FEATURES

Scope of delivery of the one-way system	Receiver
---	----------

Other

Packaging dimensions	99.0mm x 60mm x 160mm
Shipping weight	
Tariff code	85365019

Classification

ipf product group	165
eClass 8.0	27270901
eClass 9.0	27270901
eClass 9.1	27270901
ETIM-5.0	EC002716
ETIM-6.0	EC002716
ETIM-7.0	EC002716

Connection

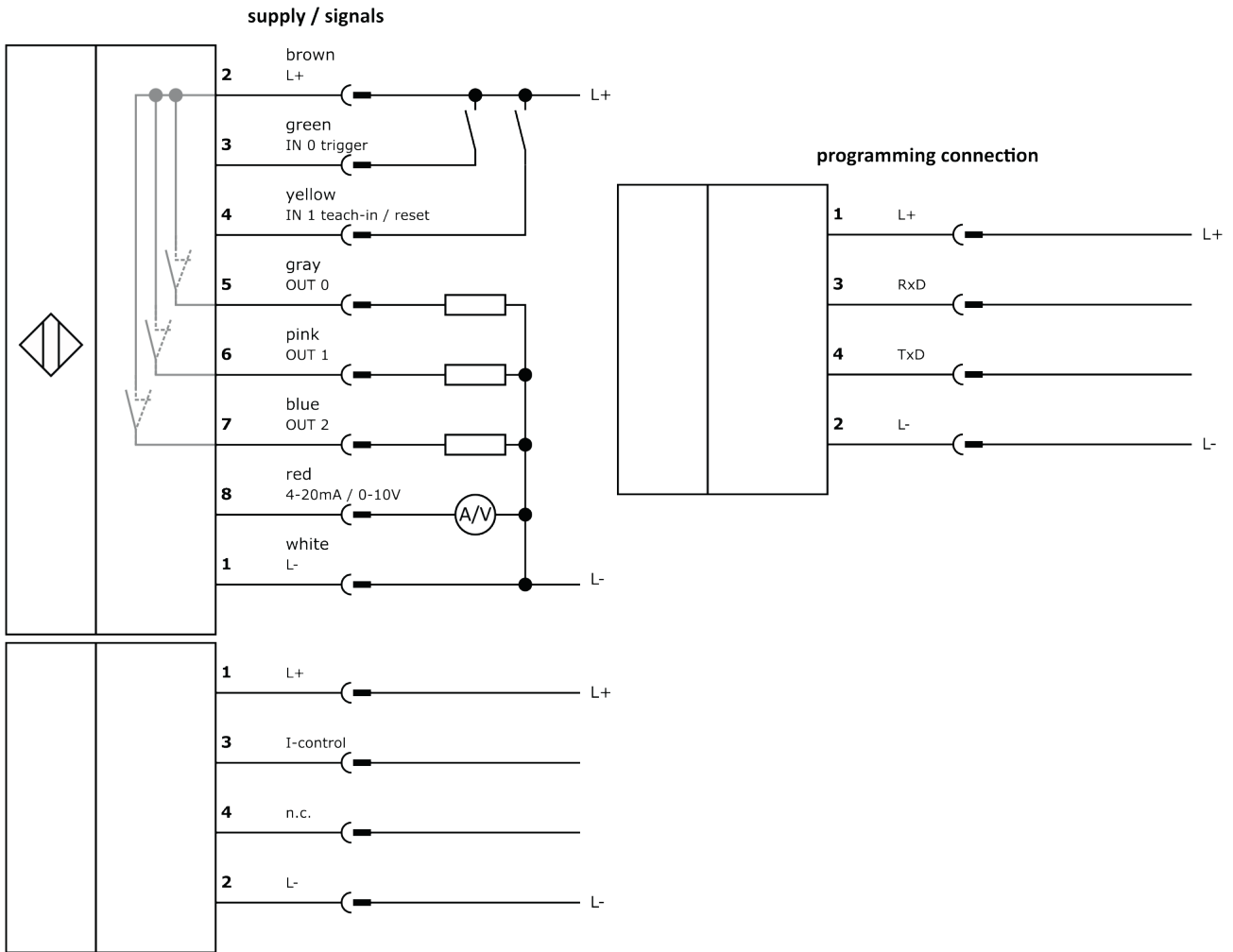

Dimensional drawing

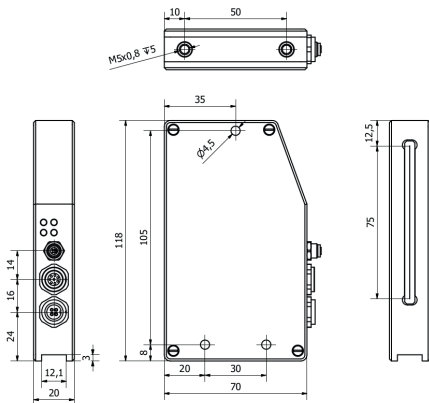

Installation



Mounting / installation may only be carried out by a qualified electrician!

Disposal



Software

Please download the software or driver required for operating your new device on our homepage: www.ipf.de

Safety warnings

Before initial operation, please make sure to follow all safety instructions that may be provided in the product information. Never use these devices in applications where the safety of a person depends on their functionality.

LED lighting systems can generate intensive UV radiation, which can damage your eyes in case of improper use. The manufacturer cannot be held responsible for damages that result from improper use or connection.