

**Manual****Level sensor – Microwave meter****Analog output****Parallel Probe****FM910023: L = 300mm****FM910024: L = 500mm****FM910025: L = 800mm**

**Contents**

- 1. Important notes..... Seite 3**
- 2. Operational description ..... Seite 3**
- 3. Installation conditions..... Seite 3**
- 4. Electrical connection..... Seite 4**
- 5. Connection to earth..... Seite 4**
- 6. Screen display and menu operation ..... Seite 5**
  - 6.1 Menu structure.....Seite 6
  - 6.2 Sub menus .....Seite 7
- 7. Maintenance..... Seite 12**
- 8. Dimensions ..... Seite 13**
- 9. Technical Data ..... Seite 13**

### 1. Important notes

- Read this operating manual carefully before connecting and commissioning the device.
- The device may only be installed and connected by a specialist authorized by the plant-manufacturer, observing the relevant safety and accident prevention regulations.
- Improper installation or use can damage the device or lead to errors in the application.
- Repairs or modifications to the device may only be carried out by the manufacturer.
- The sensor with parallel probe detects liquid media with a dielectric constant of  $\epsilon_r \geq 2.3$ .

Non suitable medias are:

- Media with large solid particles
  - Media in areas with an explosion hazard media in the foodstuffs and galvanizing industry.
  - Media with  $\epsilon_r < 2.3$
- The length „L“ of the sensor is part of the article-number.
  - Never use these devices in applications where the safety of a person depends on their functionality!

### 1. Operational description

The sensor works with the principle of the guided microwave. It measures the traveling time that a microwave takes from the sensor to the surface of the media and back. The media level is calculated from this time.

This measured fill level appears on the display. The zero point for the level measurement is the lower end of the probe. The measuring range is the distance L in the drawing (see dimensions on page 13). The analog output supplies a current of 4 to 20mA linear to the fill level. The factory setting is that 4mA is displayed, if the probe does not touch the medium, and 20mA for probe completely covered. These limits as well as the offset can be set in the menu (see section 6.2.9.).

The device display can be switched between the fill level in cm and the current output in %. If an error occurs, the output current is <4 mA.

### 3. Installation conditions

The sensor is installed perpendicularly from above in a container using the screw thread. A flat gasket has to be used for the installation. The container must have the minimum dimensions shown in the drawing. Installations in the container must have a minimum distance of 20 mm from the probe. The sensor does not require a metal flange plate.

To adjust the alignment of the display it can be rotated carefully through 360°.

Details are shown in the drawing on the next page:

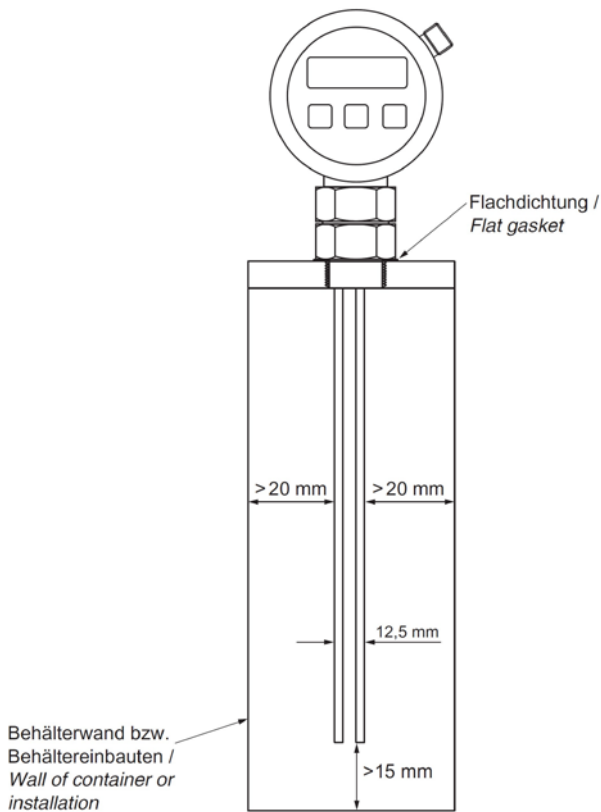

#### 4. Electrical connection

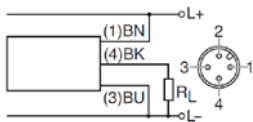

The electrical connection is made according to the circuit diagram above, observing the relevant standards. The current output must have a load resistance in the range 200 ... 500Ω. The display lights after applying the operating voltage. The device is ready, when the first measurement values appear.

#### 5. Connection to earth

In order to comply with the EMC standards, the device has to be earthed via the process connection. If the device is installed in a metal container, the container must be connected to earth. If, instead, a plastic container is to be used, the earth connection must be made, for example, by means of a metal flange plate.

## 6. Screen display and menu operation

During measuring mode, the fill level and unit are shown large in the display. If an offset is set, then the display shows fill level + offset. The actual function of the three buttons, F1, F2 and OK, are indicated directly above the respective button. In the operating manual the button's function is specified with brackets. At start, the **[MENU]** function is displayed in the measuring data display above the right button. The left and center buttons have no functionality in the measuring data display.



### User menu

The user menu is accessed via the **[MENU]** button. Its first menu item is called "OUTPUT 4-20mA".



Exit the settings menu with the **[EXIT]** function and return to the measuring data display. By selecting the **[RETURN]** function, the actual submenu or setting procedure is exited.

A submenu or menu item is accessed via the **[OK]** function.

Navigate through menu entries via the **[↓]** function. The menu structure is illustrated in the following diagram:

### 6.1 Menu structure

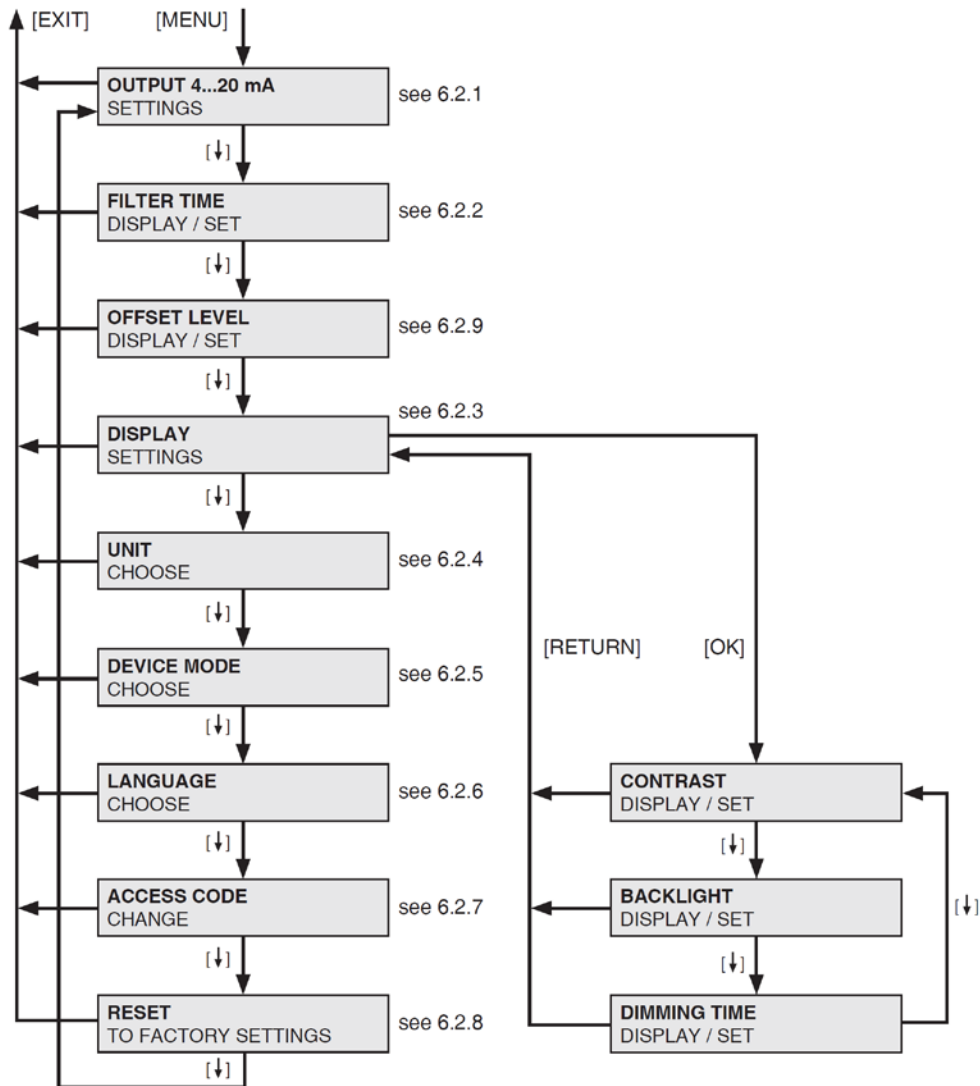

## 6.2 Sub menus

If a menu item is accessed, e.g. „Output 4-20mA“, the current value(s) is / are displayed as the next graphic shows:



If the value should be changed, then [EDIT] accesses the function. First, the access code (factory setting: 0000) has to be entered.



The last code digit displayed is increased by one with [+]. The current position can be deleted with [←] and returned to the previous. After entering the last position, [OK] ends code entry.

If the menu is not exited after entering the correct access code, then the code does not have to be re-entered to change other values.

### 6.2.1 Current output

Here the lower and upper limit for current output are set, i.e. at which fill level 4mA and 20mA are put out. The fill level is measured from the lower probe end. This limit moves with an offset  $\neq 0$  (see 6.2.9).

The positions on the probe (marked as triangles in the next graphic, the housing of the sensor appears as a symbol on the right) which show 20mA or 4mA are illustrated in the upper section of the display. The respective values are visible in the lower section of the display.



If a value has to be changed, then the [EDIT] button must be pressed and the access code entered (as described above). Subsequently the following display appears:

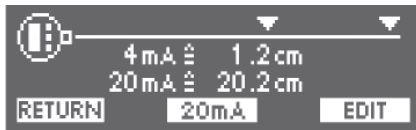

The actual selected limit for the current output is displayed with its blinking triangle marking. The limit to be set next can be selected with the centre button in the order [4mA], [20mA], [BOTH] and is indicated above that button (and not the actual selected, which is shown blinking). The [BOTH] function allows to select the 4mA und 20mA limits simultaneously.

To start the adjustment of the actual limit(s) (blinking), press the [EDIT] button. The associated display shows the following graphic:



The blinking limit(s) and associated triangular marking(s) show which value can be changed. The [←] button increases the value and the [→] button decreases it. The value is accepted with the [OK] button.

The setting range for both values is: 199.9cm ... – 99.9cm. The distance between the 4mA and 20mA has to be at least 10.0cm.

#### *Settings outside of the probe limits*

If one or both values are set outside of the probe limits, then the triangle symbol is replaced with an arrow in the display. This is illustrated in the following figure for the 4mA value. In addition, the text "< PROBE" appears behind the cm value. This shows that the set value is below the lower end of the probe.

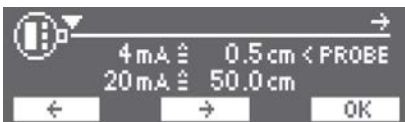

## level sensor FM91002x with parallel probe

In the next figure the 20mA value is above the upper end of the probe, illustrated by the arrow and the "> PROBE" marking.



If both values are above the upper end of the probe, then only one arrow appears:



An exception occurs if one limit is above the upper end of the probe and the second shortly before that. This is illustrated in the following figure: the 20mA value is above the upper end of the probe and the 4mA value is right in front of that. In this case, the arrow is shown on the other side, in order to make space for the triangle.



### 6.2.2 Filter time

Here can be set the time in seconds over which the measured values are averaged. The value ranges from 0.0 to 16.0s in intervals of 0.4s (0.0s; 0.4s; 0.8s; ...; 15.6s; 16.0s). 0.0s means no filtering.

### 6.2.3 Display

In the Display menu, the contrast, brightness and dimming can be set. The dimming time is the time in seconds before the screen is made darker. 0 means no dimming.

### 6.2.4 Unit

In default setting the device shows the fill level in cm. With this menu item it is possible to switch to a % display. The percentage display refers to the current output:

- 0% is the fill level, which was set for 4mA in 6.2.1.
- 100% is the fill level, which is set for 20mA in 6.2.1.

### 6.2.5 Device Mode

"Mode 1" is designed for measurement in most conditions. In special conditions (particularly long probes or media with low  $\epsilon_r$ ) measurement errors can occur. Then "Mode 2" should be used. The "Mode 2" usually works unproblematic in most cases even under normal conditions.

### 6.2.6 Language

Here you can set the menu language to English or German.

### 6.2.7 Access code

For the change of device parameters, an access code is required. This menu item allows you to set an individual access code (factory default: 0000).

### 6.2.8 Reset to factory settings

Sets the user defined settings back to factory settings (Access code too).

### 6.2.9 Offset level

The offset allows the adapting of the displayed fill level to container conditions. The value is set in cm. It is added to the current fill level, i.e. the display then shows the actual fill level + offset. Negative values are possible as well. The value range for the offset setting is:

## level sensor FM91002x with parallel probe

- Smallest offset: -99,9 cm
- Largest offset: 199,9 cm – probe length.

The offset value also affects the current output as described in the following. Therefore, settings for the current output (6.2.1) should be immediately checked after altering the offset value.

### *Current output settings with offset values $\neq 0$ :*

The display shows the actual fill level (measured from the end of the probe) plus the set offset. The current output always refers to this value on the display. If the offset is changed, then the values for the current output are automatically adjusted. Therefore the current output is not changed for the same fill level (however, the value on the display will change).

The following table and graphic (on page 12) show setting examples:

- Line 1 and figure 1: Basic settings
- In the 2nd line and figure 2, only the offset is changed from 0 to 10 cm. This value is added to the display value, so that the display changes from 40 cm to 50 cm. The current output limits are automatically adjusted to the same amount simultaneously. Therefore, the current itself remains constant.
- In the 3rd line and figure 3, offset is left constant and the current output limits are reset to the old values. The current value changes to a different one than found in the 1st line, because it refers to the (changed) display view.
- In the 4th line a negative offset is set and the current output limits are subsequently corrected by hand. Therefore the display shows a reduced value. The current output also follows this value.

	Set value for 20mA	Set value for 4mA	Set offset	Fill level example	Display view	Current at the output	No. in the figure
1.	<b>50cm</b>	<b>0cm</b>	<b>0cm</b>	40cm	40cm	16,8mA	1
2.	60cm*	10cm*	<b>10cm</b>	40cm	50cm	16,8mA	2
3.	<b>50cm**</b>	<b>0cm**</b>	10cm	40cm	50cm	20,0mA	3
4.	<b>50cm**</b>	<b>0cm**</b>	<b>-10cm</b>	40cm	30cm	13,6mA	

**Bold:** manually set values, different to previous lines.

\* Set limits have changed due to adjusted offset values.

\*\* After setting the offset value, these limits are then set to specified values by hand.

Fig. 1: Basic setting

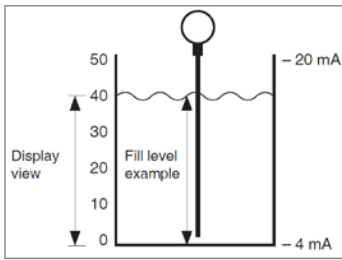

Fig. 2: Offset is set

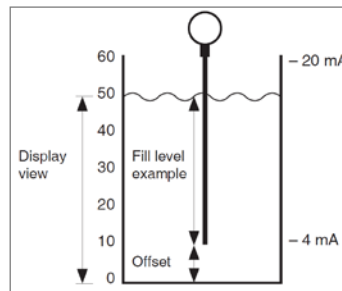
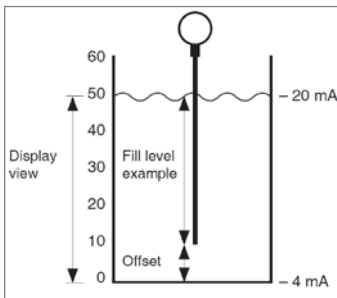

Fig. 3: Adjusting the current output



### Effect on the display

The triangle markings (see 6.2.1) refer to the positions of the respective limit in relation to the probe. This means that offset value have changed during adjustment.

Example: The position of the triangle for the 4mA value = 10cm, offset = 10cm is the same as for the 4mA value = 0 cm, offset = 0 cm (see figure 1 and 2).

## 7. Maintenance

The only maintenance necessary for the sensor is the regular inspection for soiling and then cleaning, as necessary.

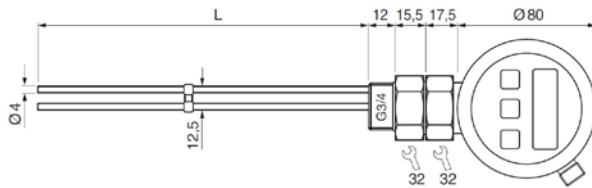
**8. Dimensions**

**9. Technical Data**

Container connection	G3/4 thread
Supply voltage	20 ... 27V DC
Current consumption (without Last)	< 45mA
Analog output	4 ... 20mA
Load resistance	200 ... 500Ω
Dielectric constant of the medium	$\epsilon_r \geq 2,3$
Precision	better than illustrated in the diagram
Display	cm or %
Compressive strength (25°C)	10bar
Ambient temperature	0 ... +70°C
Medium temperature	0 ... +80°C
System of protection (EN 60529)	IP 67
Housing material	Aluminium
Materials	AISI 316 Ti / PTFE / POM
Sealing material	NBR / AFM 34
Connection	M12 connector 4-pin
Connection Accessories	e.g. <b>VK205325</b>
Access code factory default	0000

**Measuring precision (standard conditions)**
