

## BA565900

### MEASURING TRANSDUCERS • MEASURING TRANSDUCERS



#### MECHANICAL DATA

Ambient temperature (MAX)	70 °C
Ambient temperature (MIN)	-40 °C
Degree of protection (IP)	IP20
Height	99 mm
Housing material	PC
Length	114 mm
Storage temperature	100 °C
Storage temperature	-40 °C
Suitable for serial installation	Yes
Width	22.5 mm

#### ELECTRICAL DATA

Analog input, current	Yes
Analog input, voltage	Yes
End value measuring range, current	0.02 A
Initial value of measuring range, current	0 A
Integrated configuration function	No
Max. continuous current	6 A
Max. switching current	10 A
Power consumption	1.75 VA
Rated control supply voltage $U_s$ at AC 50HZ (MAX)	253 V
Rated control supply voltage $U_s$ at AC 50HZ (MIN)	20 V
Rated control supply voltage $U_s$ at DC (MAX)	253 V
Rated control supply voltage $U_s$ at DC (MIN)	20 V
Relative measurement accuracy	0.4 %
Resistance of current input	50 Ohm
Resistance of voltage input	100 kOhm
Reverse polarity protection	Yes
Setting procedure	Manual adjustment
Short-circuit-proof	Yes
Suitable as 2-point control	Yes

**ELECTRICAL DATA**

Type of analog input	0 V ... 10 V / 4 mA ... 20 mA / 0 ... 20 mA
Type of electrical connection	Clamp
Type of switching output	Relay contact
Voltage type	AC/DC
With switching output	Yes

**DIMENSIONAL DRAWING**

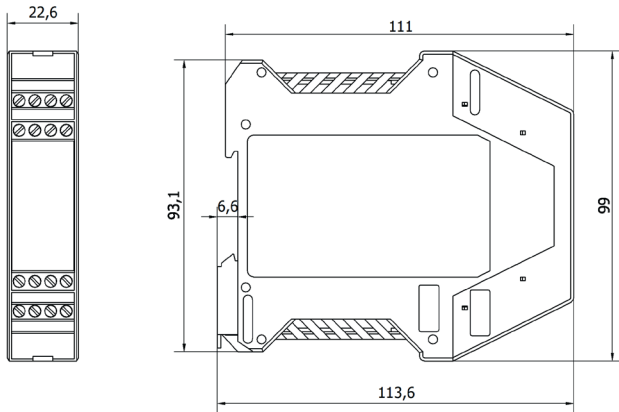

**INSTALLATION**



Mounting / Installation may only be carried out by a qualified electrician!

**DISPOSAL**



**SAFETY WARNINGS**

Before initial operation, please make sure to follow all safety instructions that may be provided in the product information!

Never use these devices in applications where the safety of a person depends on their functionality.