

dimensions 22.5 x 75 x 110mm

multi-function

- ON delay
- ON delay, instant with passing make contact
- OFF delay
- clocking, start with pulse
- clocking, start with break
- pulse shaping
- star/delta switchover

- ✓ functions and time ranges adjustable using DIP switch
- ✓ large time ranges with high repeat accuracy
- ✓ 2 internal relays / change-over contacts
- ✓ external operation using remote potentiometer
- ✓ wide-range power supply
- ✓ DIN housing for attaching to DIN rail
- ✓ LED function display



**multifunction time delay relay
8 functions and time ranges**

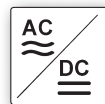

description

The times and functions of the output relays are set using the DIP switches on the front. Eight functions are available, see diagrams on the following pages. The potentiometer on the front panel is used for fine adjustment of the times. The times can be adjusted in 8 ranges of 0.1 seconds to 300 minutes. One green and one red light emitting diode (LED) are used to indicate the operating mode. The green LED indicates operational readiness. The red LED indicates that relay 1 has energized. In the star/delta function, the red LED also illuminates when relay 2 energizes.

After applying the operating voltage, the internal processor loads the function that has been selected using the DIP switches and the basic time range. Changes to the DIP switches do not take effect until the operating voltage has been interrupted and reapplied. Changes to the time-settings using the potentiometer are also recorded during operation.

The housing is attached to a 35mm DIN rail. The operating voltage is connected to terminals A1 and A2. The make contacts (terminals) of the two integrated relays can be freely wired. They operate in different ways depending on the selected

function. The potential-free transducer contact that is required in some functions is connected to terminals B1 and B2. If no potential-free contact is available an external control voltage is connected to terminal B2, which must correspond to the potential at A1.

The remote potentiometer is connected to the terminals Z1 and Z2. It is automatically recognized by the device when the operating voltage is applied. The maximum resistance of the encapsulated potentiometer is 10kΩ. The feed line must be shielded and earthed, and must not exceed a length of one meter.

application examples

- ▶ Automatic start-up control for motors
- ▶ Lighting controllers
- ▶ Fan controller
- ▶ Traffic light controller
- ▶ Elevator and escalator controllers
- ▶ Time-controlled processes
- ▶ On-time working

article-no.

ZM565453

version

multifunction time delay relay

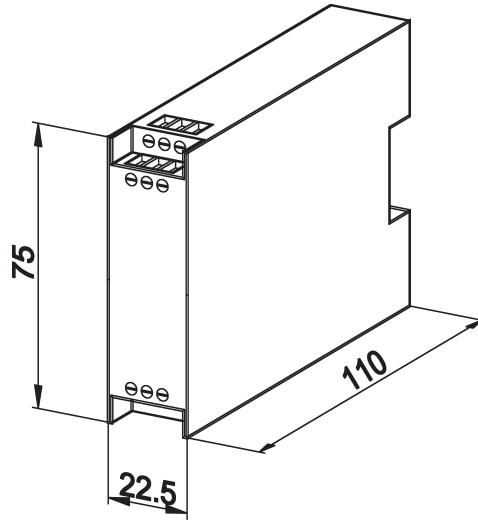

TECHNICAL DATA

function	multifunction time delay relay
output	relay output, 2 change-over contacts, inrush current 7A, continuous current 3A, cut-off current 2A
operating voltage	24V AC/DC ... 240V AC/DC
power consumption	1 ... 5VA
control signal at B2	10V AC/DC ... 300V AC/DC
contact life	for 0.5A approx. 2.5×10^7 operating cycles
relay release time	approx. 20ms
repeat accuracy	approx. ± 10 ms
temperature dependency	< 0.1%/Kelvin
recovery time	approx. 110ms
display	green LED, red LED
time adjustment	potentiometer: 0.1s ... 300min / analog / 8 time ranges
dimensions	22,5x75x110mm
housing	12-pin insulation material housing
housing material	polycarbonate
installation depth	approx. 133mm
operating temperature	-20°C ... +60°C, no condensation allowed
degree of protection (EN 60529)	housing IP40 / terminals IP20
connection (terminals)	safe to touch in accordance with VDE 0100 and VBG 4, max 4mm ²
mounting	35mm DIN rail (DIN EN 60715 TH35)

time function:	ON delayed	ON delay, instant (relay2)	ON passing make contact	OFF delayed	clocking, start with pulse	clocking, start with break	pulse forming	star/delta switchover
S1	OFF	ON	ON	OFF	OFF	ON	OFF	ON
S2	OFF	OFF	ON	ON	OFF	OFF	ON	ON
S3	OFF	OFF	OFF	OFF	ON	ON	ON	ON

time range:	0.1sec-1sec	0.5sec-10sec	5sec-60sec	30sec-120sec	1min-5min	3min-10min	5min-60min	30min-300min
S4	OFF	ON	OFF	ON	OFF	ON	OFF	ON
S5	OFF	OFF	ON	ON	OFF	OFF	ON	ON
S6	OFF	OFF	OFF	OFF	OFF	ON	ON	ON

ON delay

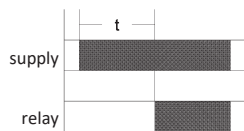

ON delay with instant contact

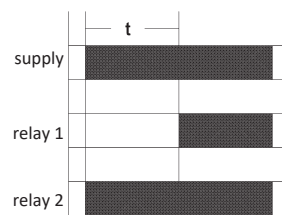

passing make contact

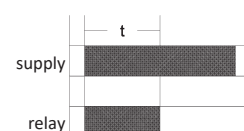

OFF delay

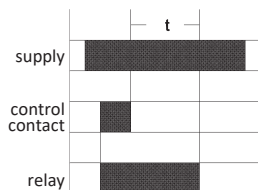

clocking, start with pulse

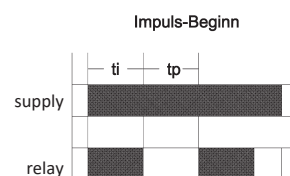

clocking, start with break

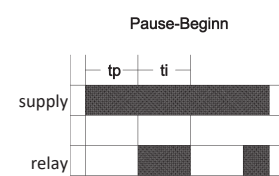

Pulse forming

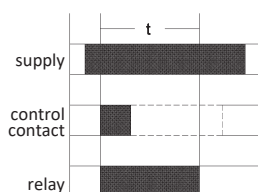

star / delta switchover

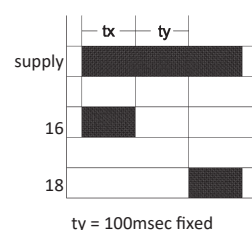

Notes

- When operating with DC voltage, connect positive pole to terminal A1.
- Terminal B1 always has the same potential as terminal A1 (possibly mains voltage).
- Note the adjacent technical data.
- A remote potentiometer with metal axis must be earthed.
- Operation is only permitted with the plexiglass cover fitted.
- After installation, no manipulation with tools is allowed with the device switched on.

connection

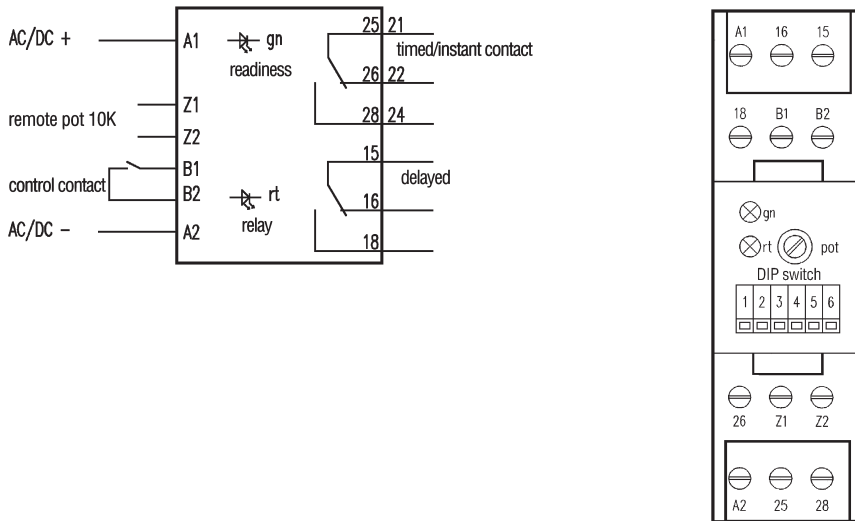

accessories

AZ000004

AZ000005

AZ000006



article-no.	Description	Note
AZ000004	time delay relay, remote potentiometer 10kΩ, 10r and	soldered connection
AZ000005	time delay relay, remote potentiometer 10kΩ, 22.5r and	soldered connection
AZ000006	time delay relay, remote potentiometer 10kΩ, 22.5r and	screw connection

Warning: Never use these devices in applications where the safety of a person depends on their functionality.

This data sheet as well as your personal contact can be found at www.ipf-electronic.com