

IP69k tubular protection for safety light curtains

GENERAL INFORMATION

AO000201 ... AO000212 accessory, is a PMMA acrylic tube used to protect and seal the safety light curtains of OY32 and OY36 series. Thanks to this accessory the IP protection of the safety light curtain is increased from IP65 to IP67, IP68 and IP69K.

The Gore-Tex membrane on the caps prevents entry of water or dirt and prevents the presence of condensation inside. The connection cable for light curtain is protected and kept in to his side by a metric chock M16 that prevents the entry of water or dirt.

2 stainless steel rotating brackets, to be mounted on the product caps, are provided and guarantee a quick and easy installation.

Highlights

- IP67, IP68 and IP69K protection
- PMMA acrylic tube
- Unique profile with different lengths suitable for all controlled heights of OY32 Series (150 - 1800 mm) and OY36 series (2, 3 and 4 rays).
- Does not compromise the performance of the light curtain in terms of alignment.
Do not change the EAA value.

Typical Applications

The AO000201 ... AO000212 accessory is particularly used where high levels of humidity and temperature are present and machines or equipments are frequently washed with hot water (up to 80°C) at high pressure (up to 100bars) and / or cleaned with detergents.

AO000201 ... AO000212 is particularly suitable for FOOD industry applications: beverage production, meat slaughter, sausage production, milk / cheese industry, etc. ...

Package Contents

The package contains the following items:

- a) PMMA transparent tube (1 pcs)
- b) Lower assembled support (1 pcs)
- c) Upper assembled support (1 pcs)
- d) Closing cap with silicone compound OR (2 pcs)
- e) INOX rotating brackets (2 pcs.)
- f) Nuts and bolts
 - M5 square nut (4 pcs)
 - TE M5x6 UNI 5739 screw (4 pcs)
 - UNI 8842 J5 metallic elastic washer (4 pcs)
 - INOX TCEI M4x8 UNI 5931 screw (6 pcs)
 - A4 UNI 8840 ZB metallic washer (6 pcs)
 - INOX TCEI M4x18 UNI 5931 screw (8 pcs)

ASSEMBLY INSTRUCTIONS

First of all, remove closing caps **d** from sub-assemblies **b** and **c** then remove the aforementioned **b** and **c** from tube **a**. After these operations you have to obtain the situation shown in Fig.1.

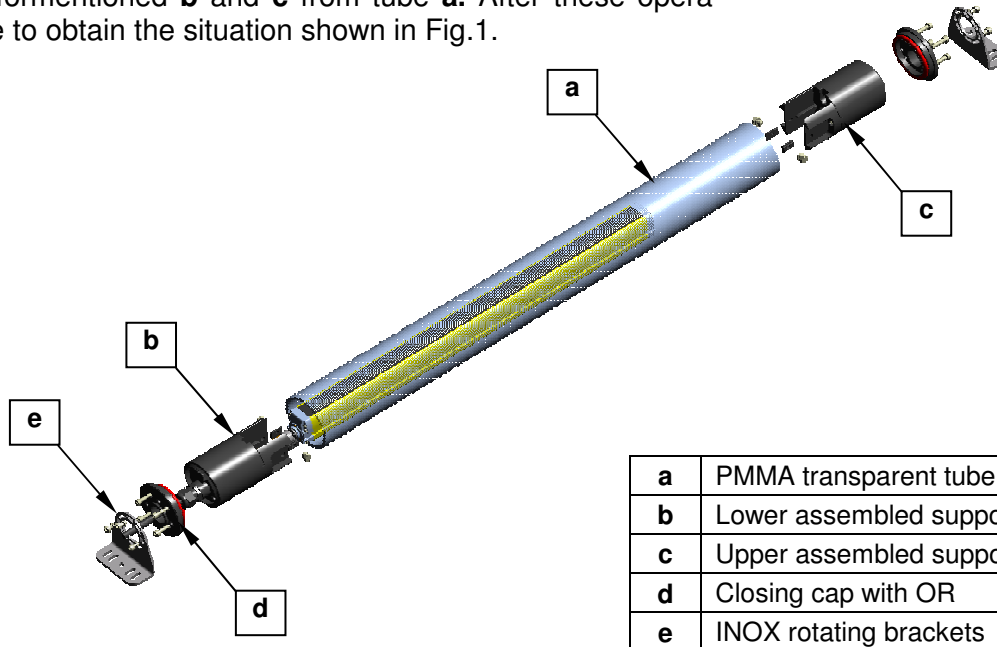

a	PMMA transparent tube
b	Lower assembled support
c	Upper assembled support
d	Closing cap with OR
e	INOX rotating brackets

Fig. 1

Place the M5 square nuts on the inner side of the support wings, aligned with the holes and fix them not completely with the TE M5x6 UNI 5739 screws (and special washers) in order to leave them a moving range (Fig. 2 and Fig. 3).

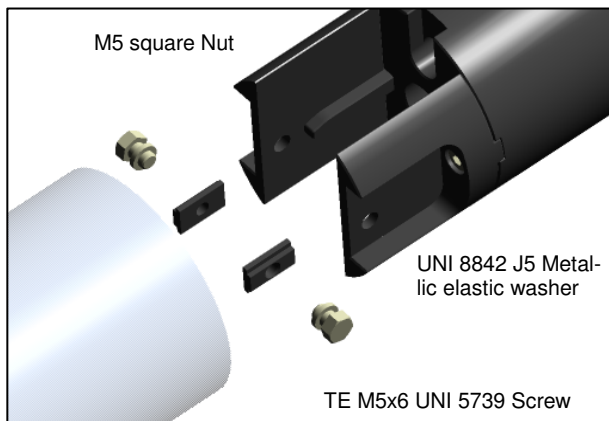

Fig. 2

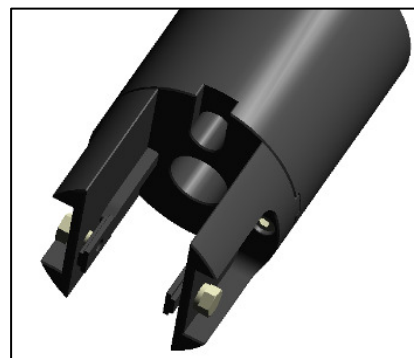
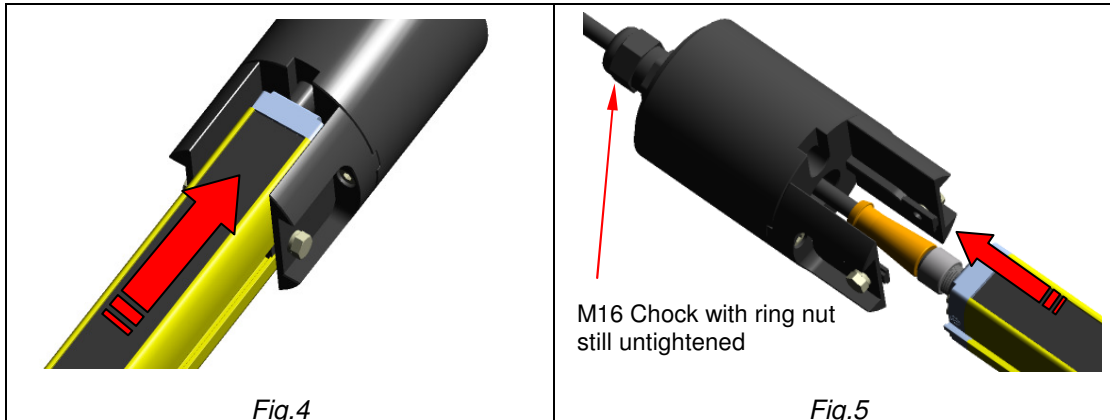

Fig. 3

IP69k tubular protection for safety light curtains

Then, insert the adapters in the safety light curtain lateral grooves (Fig. 4) until you reach the back side, and then fully tighten the screws to fix the curtain to **c**. Repeat the same operation also for **b** part, keeping attention to pass safety light curtain cable (that must be connected to the curtain before starting this assembly procedure) through the hole corresponding to M16 chock before completely tighten the screws (Fig. 5).



When both part **b** and **c** are completely installed with the curtain finally firmly tighten the chock nut to fix the cable. Check once again that the M5x6 UNI TE 5739 screws are well locked on their elastic washers.

Once the system appears like shown in the Fig. 6 it can then be inserted inside the transparent tube (Fig. 7).

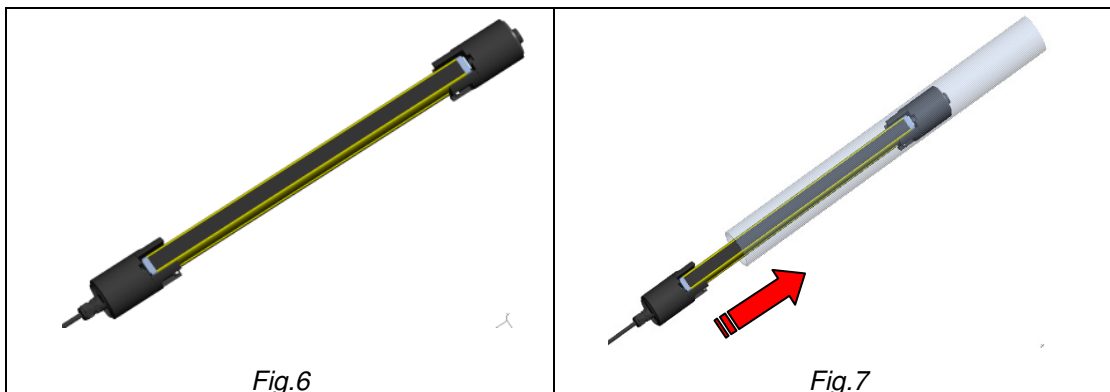

At this point, you have to prepare the 2 closing caps with corresponding OR gasket, as in Fig. 8, and then apply them to both upper and lower sides of the PMMA tube.

Complete the mounting tightening the 4 INOX TCEI M4x18 UNI 5931 screws for both sides for the complete compression of the OR seal against the tubular inner surface (Fig. 9).

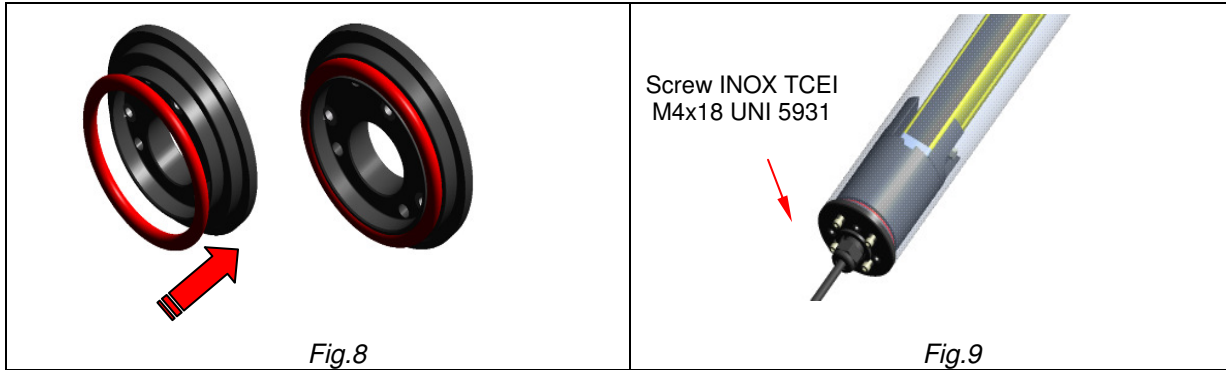

For brackets mounting place them on both caps aligned to appropriate bracket's central hole, and then lock in the desired angular position, with 3 INOX TCEI M4x8 UNI 5931 screws (Fig. 10).

The bracket is designed to allow all the "main" positions, with intermediate angular adjustment range within 20 and 30 degrees depending on the position required (Fig.11 and Fig.12).

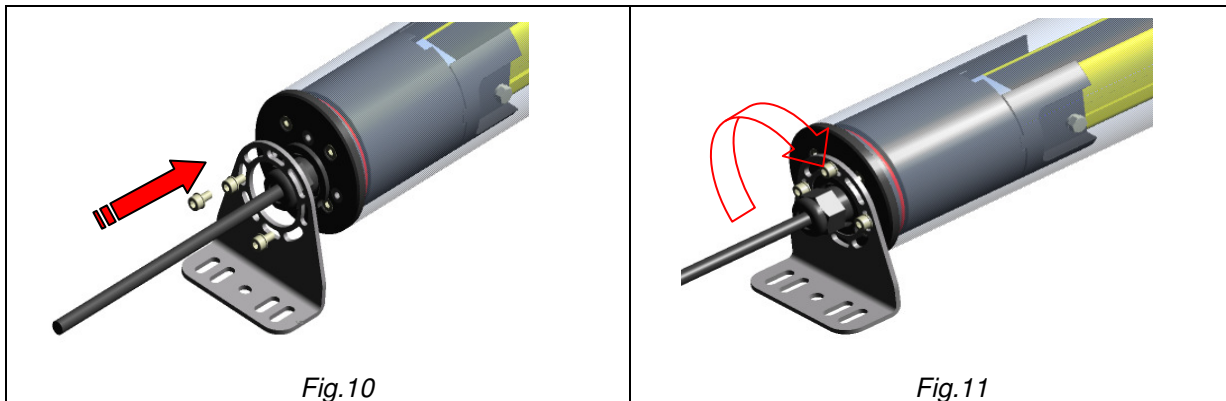

IP69k tubular protection for safety light curtains

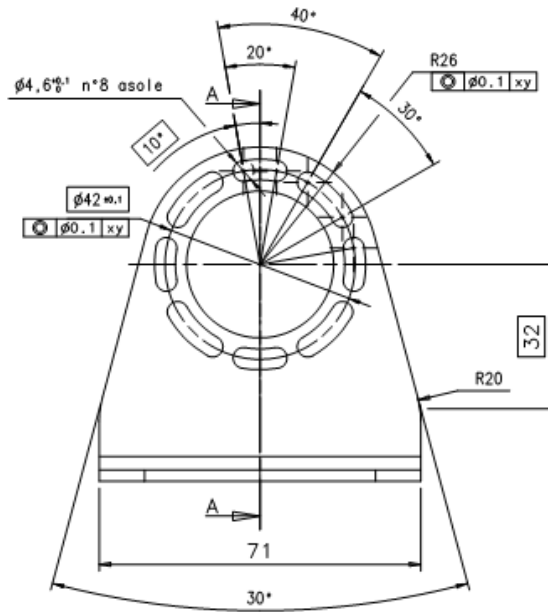

Fig. 12

Technical Data

OPTICAL DATA	
Operative distance / reduction factor:	10% for each unit
EAA aberration (<i>Effective Aperture Angle</i>):	None
MECHANICAL DATA	
Body material:	Weep-Spin-Dry Policril PMMA
Thickness:	4mm
Protection grade:	IP67, IP68 and IP69K

Available Models

Model	Description
AO000201	Tubular IP69K H=150mm
AO000202	Tubular IP69K H=300mm
AO000203	Tubular IP69K H=450mm
AO000204	Tubular IP69K H=600mm
AO000205	Tubular IP69K H=750mm
AO000206	Tubular IP69K H=900mm
AO000207	Tubular IP69K H=1050mm
AO000208	Tubular IP69K H=1200mm
AO000209	Tubular IP69K H=1350mm
AO000210	Tubular IP69K H=1500mm
AO000211	Tubular IP69K H=1650mm
AO000212	Tubular IP69K H=1800mm

IP69k tubular protection for safety light curtains

DIMENSIONS

The overall dimensions of the complete product for all available models are shown below.

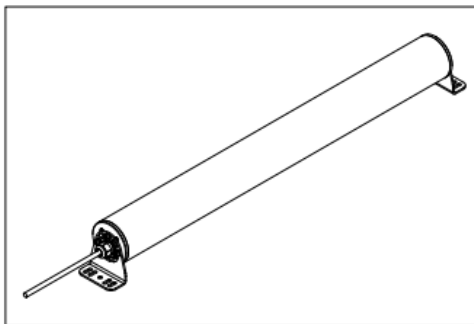
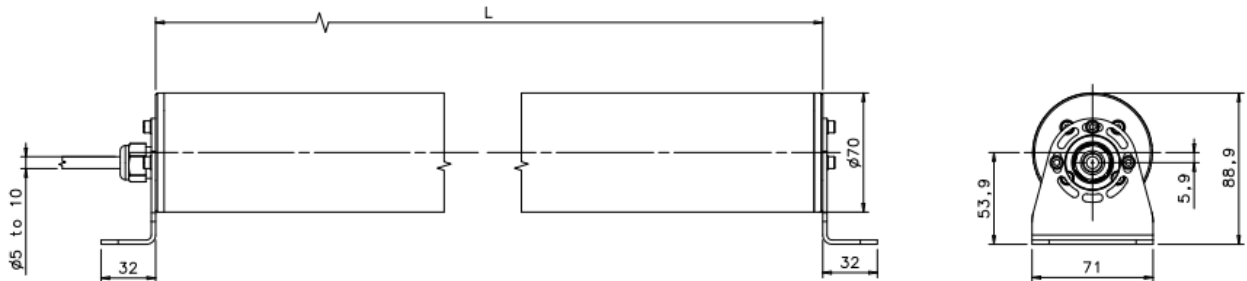

Model	L [mm]
AO000201	373,5
AO000202	520,7
AO000203	670,8
AO000204	820,7
AO000205	970,8
AO000206	1120,7
AO000207	1270,7
AO000208	1420,8
AO000209	1570,7
AO000210	1720,8
AO000211	1870,8
AO000212	2020,8