

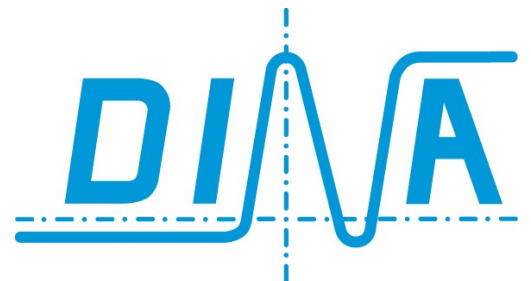

# SAFELINE

Original Instruction Manual

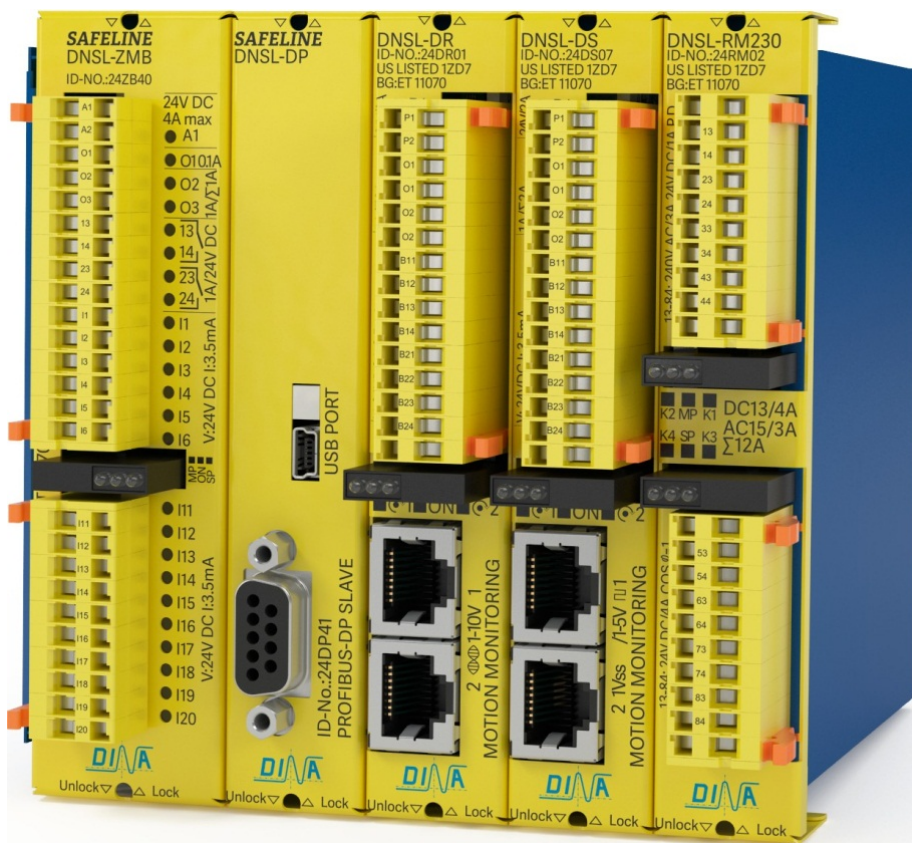

we are safety.



EU-Konformitätserklärung	EU declaration of conformity	
Déclaration UE de conformité	Dichiarazione di conformità UE	Declaración UE de conformidad

Die nachfolgend aufgeführten Produkte sind konform mit den Anforderungen der folgenden Richtlinien  
The beneath listed products are in conformity with the requirements of the following directives  
Les produits mentionnés ci-dessous sont conformes aux exigences imposées par les directives suivantes  
I prodotti sotto elencati sono conformi alle direttive sotto riportate  
Los productos listados a continuación son conforme a los requisitos de las siguientes directivas

Maschinenrichtlinie	2006/42/EG	EMV Richtlinie	2014/30/EU	RoHS-Richtlinie	2011/65/EU
Machinery directive	2006/42/EC	EMC Directive	2014/30/EU	RoHS Directive	2011/65/EU
Directive Machines	2006/42/CE	Directive de CEM	2014/30/UE	Directive de RoHS	2011/65/UE
Direttiva Macchine	2006/42/CE	Direttiva EMV	2014/30/UE	Direttiva RoHS	2011/65/UE
Directiva de máquinas	2006/42/CE	Directiva CEM	2014/30/UE	Directiva RoHS	2011/65/UE

Folgende Normen sind angewandt:	a	• EN 55011: 1998+A1: 1999+A2: 2002, EN 55011: 2009+A1 2010 (class B)
Following standards are used:	b	• EN 62061: 2005
Les normes suivantes sont appliquées:	c	• EN 61326-3-1: 2008 (SIL3)
Vengono applicate le seguenti norme:	d	• EN 61000-6-2: 2005
Se utilizan los siguientes estándares:	e	• EN 1760-01: 1997
	f	• DIN EN 60947-5-1: 2010-04
	g	• DIN EN ISO 13849-1: 2008-12, (category 4/ PL e)
	h	• DIN EN ISO 13849-2: 2008-09
	i	• DIN EN 62061: 2005-10, (SILCL 3)
	j	• DIN EN 574: 2008-12 (Type IIIC) / (Type IIIA)

Zusatzanforderung: Supplementary requirements:	<ul style="list-style-type: none"> <li>• DGUV Test: GS-ET-20: 2009-01</li> <li>• DIN EN ISO 9001: 2015</li> </ul>
---	---

EG-Baumusterprüfbescheinigung: ET 16110/ 12.08.2016 EC-Type Test certificate: ET 16110/ 2016-08-12

	SAFELINE		
Bezeichnung der Bauteile	DNSL-ZM, ZMA, ZMB, ZMK, ZMT, ZMR	Zentralmodule	Central modules
Description of components	DNSL-DS, -DR, -SIV	Drehzahlüberwachungen	Speed monitoring
Description des composants	DNSL-IN, -IO, -IO2, RM 230, KM	Ein- Ausgangsmodule	In- output modules
Descrizione dei componenti	DNSL-CI, CM	Kaskadenmodul	Cascade module
Descripción de componente	DNSL-FB: -DP, -EC, -CO (class A)	Feldbusmodule	Field bus modules

Notifizierte Stelle	DGUV TEST, Prüf- und Zertifizierungsstelle, Elektrotechnik, Kenn-Nummer: 0340
Notified body	ELMAC GmbH Bondorf, Reg. Nr.: DAT-P-206/05-00
Organisme notifié	UL: File E227037
Organismo notificato	DQS, Frankfurt, Reg.-Nr.:67542-01
Organismo notificado	

Wolfschlugen, 24. September 2018



Dirar Najib

# SAFELINE

The direct way to safe automation

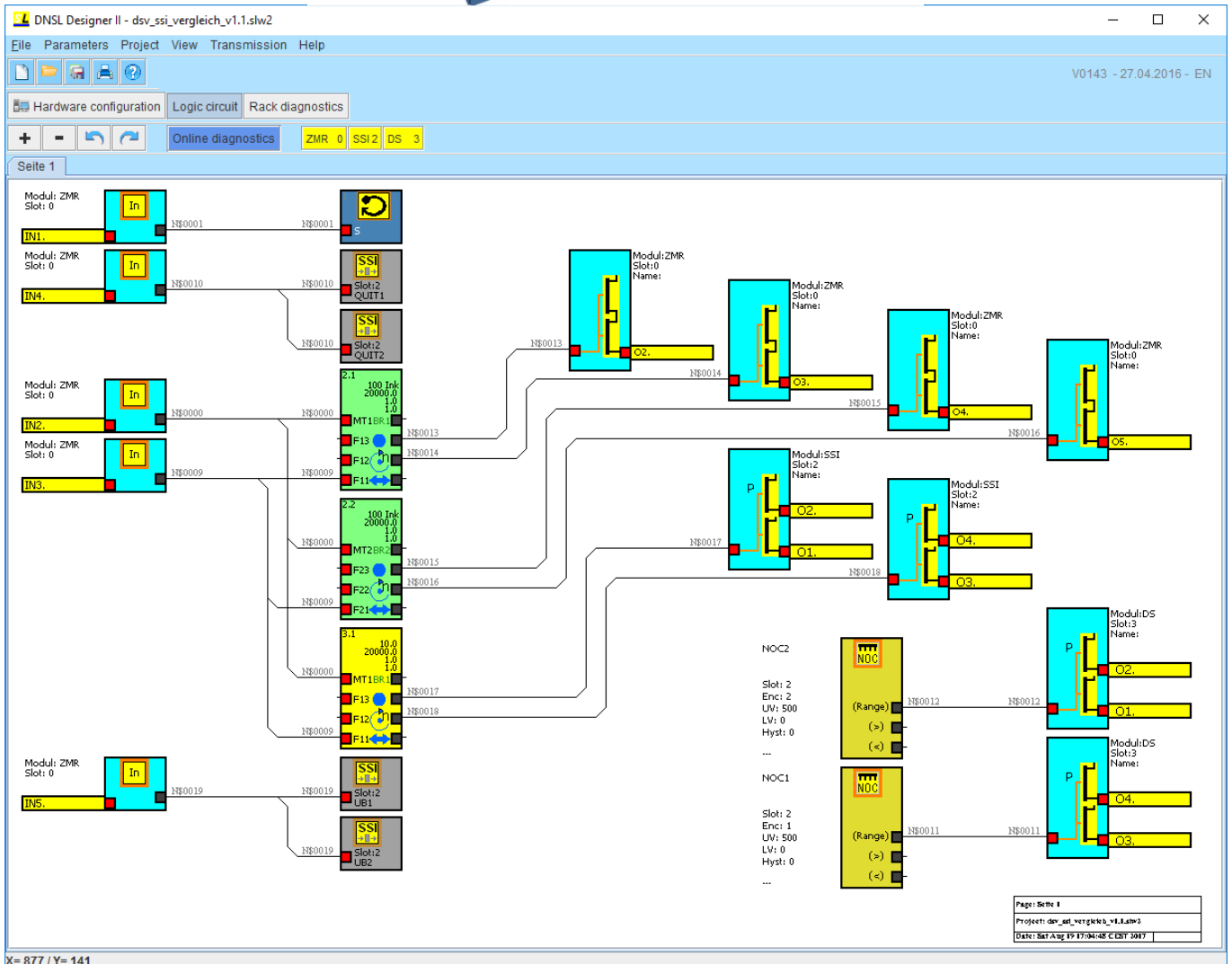
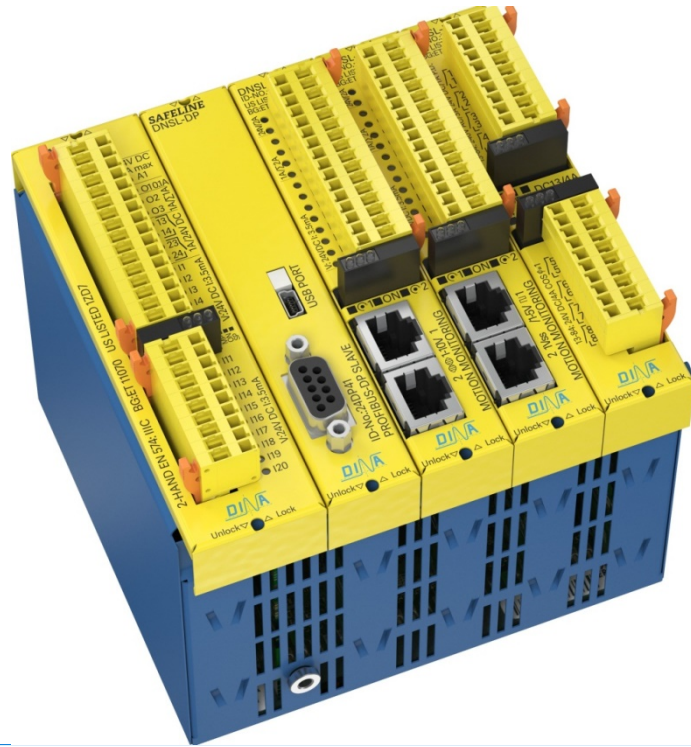

X= 877 / Y= 141

1	SAFELINE Modules .....	6
1.1	Intended purpose .....	6
2	Safety regulations .....	7
2.1	Important notes and validation .....	7
3	Product description .....	8
o	<b>Behaviour with errors</b> .....	8
4	Mounting .....	9
5	Central modules.....	10
5.1	Schematic and display .....	10
5.2	Front view of the central modules .....	11
6	Field busses and interfaces.....	11
7	Standstill and speed monitoring.....	12
7.1	Schematic, display and front view .....	12
8	In-, output modules.....	13
8.1	Schematic, display and front view .....	13
9	Kaskadierung über DNSL-CI und DNSL-CM .....	14
10	Networking using DNSL-NI .....	15
11	Inputs for safety functions .....	16
11.1	Safe Shutdown mat functions using I16 – I20 at DNSL-ZMT .....	16
11.2	Input for function mode switch (FMSS) at the central module.....	16
11.3	Input for Tow-Hand functions according to EN 574: Type IIIC.....	16
11.4	Eingänge für Sicherheitskreise (SK) mit manuellem Quitt .....	17
11.5	Inputs for safety circuit without quit input .....	18
11.6	Quit for safety circuits (SC) .....	18
12	Standstill and speed monitoring.....	18
12.1	Standstill and speed monitoring at DNSL-ZMB/ ZMR/ ZMT .....	18
12.2	Requirement at Proximity sensors.....	18
12.3	Standstill and speed monitoring using DNSL-DS .....	19
12.4	Requirement at the Measuring system .....	19
12.5	Standstill and speed monitoring using 2 Sensors for measuring system .....	19
12.6	Standstill and speed monitoring using DNSL-DR .....	19
12.7	Standstill and speed monitoring using DNSL-SI .....	20
12.8	Quit of the speed monitoring.....	20
12.9	Brake monitoring with DSV, DRV, SIV .....	20
12.10	Direction monitoring with DNSL-DSV, DRV and SIV .....	20
12.11	DNCO Function to monitor the Peripheral speed .....	21
12.12	Analogue inputs for DNCO-function at DNSL-ZMA .....	21
13	Cable adapter.....	21
14	Data in- and outputs at the field bus.....	22
15	Outputs at SAFELINE .....	23
16	General technical data .....	24
16.1	Electrical characteristics .....	24
16.2	Semiconductor outputs at the central module.....	24
16.3	Semiconductor outputs at the function modules .....	24
16.4	Contact outputs at at SAFELINE.....	25
16.5	Electrical life of the contact outputs .....	26
17	Dimension and installation .....	27
17.1	Rack variants.....	27



## 1 SAFELINE Modules

Central module	Speed monitoring	In-, output modules	Relay modules	Field bus modules	Network modules
DNSL-ZM DNSL-ZMA DNSL-ZMB DNSL-ZMK DNSL-ZMR DNSL-ZMT	DNSL-DS DNSL-DR DNSL-SI	DNSL-IN DNSL-IO DNSL-IO2 DNSL-RM DNSL-KM	DNSL-RM DNSL-KM	DNSL-CO DNSL-DP DNSL-EC etc	DNSL-NI

### 1.1 Intended purpose

- Testing based on:
- EN 55011: 2009+A1 2010 (class B), EN 61326-1: 2006-05 SIL3, EN 61000-6-2: 2006-05, EN 62061: 2005, EN 61326-3-1: 2008
- DIN EN 60947-5-1 (2010-4): Low-voltage switch gear and control gear; part 5.1: Control circuit devices and switching elements - electromechanical control circuit devices
- EN ISO 13849-1 (2016-06): Safety-related parts of control systems; Part 1: General principles for design (category 4, PL e, ET 16110 from 2016-08-012)
- DIN EN ISO 13849-2: Safety-related parts of control systems; Part 2: Validation
- DIN EN 574 (2008-12): two-hand control devices type III C using contact outputs type III A using semi-conductor outputs
- GS-ET-20 (2014-10): Basic principles for testing and certification of safety switch devices

Authorized person for the combination of the technical documents: Dirar Najib, CEO,  
Esslinger Str. 84, D 72649 Wolfschlugen  
Wolfschlugen, 2016-08-15Zertifizierungsdaten

EN ISO 13849-1: Category 4, PL e EN 574: two-hand function MTTF <sub>D</sub> : 75 years DC <sub>avg</sub> : ≥ 90% PFH <sub>D</sub> : 6,24x10 <sup>-8</sup> CCF: 85 points, DIN EN 62061 CCF: 95 points, T <sub>M</sub> : 20 years		
---	---	--

Certificated by: (Fachausschuss für Elektrotechnik, Prüf- und Zertifizierungsstelle Köln)

European notified institution, Identification-number 0340, EC-Type Test certificate (DGUV Test: ET 16110 from 12-08-2016)

EMC-directive certificated by "ELMAC GmbH Bondorf", Reg. No.: DAT-P-206/05-00

CNL, USL: File E227037

QM System certificated according to DIN EN ISO 9001:2015 by "DQS, Frankfurt", Reg.-No.: 67542 QM08

Certificate and declaration of conformity: See [www.dina.de](http://www.dina.de)

## 2 Safety regulations

- The device may only be installed and commissioned by an electrician or trained persons who are familiar with these operating instructions and the applicable regulations regarding work safety and accident prevention.
- Observe the VDE, EN and local regulations, particularly with respect to the protective measures.
- Failure to observe the regulations may result in death, severe bodily injury or extensive property damage.
- For emergency-stop applications, either the integrated function for restart interlock must be used or automatic restarting of the machine must be prevented by means of a higher-level control.
- During transport, storage and operation adhere to the conditions specified in EN 60068-2-1, 2-2!
- Unauthorized modifications shall render any warranty null and void.
- Dangers may thereby arise that could result in severe injuries or even death.
- Install the device in a control cabinet with a protection class of at least IP54! Dust and moisture may otherwise result in impaired functions.
- Installation in a control cabinet is mandatory.
- Ensure adequate protection circuits at output contacts for capacitive and inductive loads!
- The device is to be installed taking into account the distances required per DIN EN 50274, VDE 0660-514.
- During operation, switching devices carry dangerous voltage. Do not remove protective covers.
- Replace the device after the first malfunction!
- Properly dispose of the device at the end of its service life. 
- If these regulations are not adhered to or in the event of improper use, DINA Elektronik GmbH accepts absolutely no liability for the resulting property damages or personal injury.
- Save this product information!

### 2.1 Important notes and validation

- The product described here was developed to perform safety related functions as part of a complete system.
- The complete system consists of sensors, evaluation and message units as well as concepts for safe shutdowns.
- It is the responsibility of the manufacturer of a system or machine to ensure the proper overall function.
- The manufacturer of the system is required to test and to document the effectiveness of the implemented safety concept within the complete system.
- This verification is to be performed after every modification to the safety concept or to safety parameters.
- DINA Elektronik is not in the position to guarantee the properties a complete system that was not designed by DINA.
- DINA Elektronik GmbH also accepts no liability for recommendations that are given or implied by the following description.
- No new guarantee, warranty or liability claims that extend beyond DINA's general delivery conditions can be derived on the basis of the following description.
- To avoid EMC disturbances, the physical environmental and operating conditions at the installation location of the product must comply with section EMC of DIN EN 60204-1.
- The safety function must be required every month if there is performance level (e) and every year if there is PLd is required by using contact outputs.
- The information in the general technical data at the end of the operating instructions must be adhered to.

### 3 Product description

- SAFELINE is appropriated to be used in machines and plants to protect the operator against potential dangers and plants against destruction.
- SAFELINE is housed in a metal rack. It can be mounted by spring fasteners to a DIN rail.
- The individual modules are pluggable. The number of the used modules set the rack width. Up to 15 modules can be used.
- Racks with 2, 3, 5, 7, 9, 13 and 15 slots are available.
- Unused slots are closed with a blind cover. ID-No.: 10BD00
- All modules are connected by 2 backplane bus system.
- To fulfil the requirements of the wide ranges of needs different modules with diverse functions are available.
- SAFELINE is deliverable with different field bus modules.
- A variety of safe functions are available such as logic modules, timers, safety circuits, mode selector, generator, counters, comparators, feedback, restart interlock etc.
- A lot of safe digital and analogue inputs, safe semi-conductor outputs and contact outputs are available.
- Semi-conductor outputs are overload and short circuit proofed.
- The switching status of all I/O terminals and supply voltage are indicated by LED.
- The power supply (24V DC) is connected to the terminals A1/ A2 at the central module for all modules.
- To supply the semi-conductor outputs at the function modules with 24V DC the terminal P is designated.
- The user application is configurable with the SAFELINE Designer on a PC. The application is transferred by the USB or V24 interface at the central module. The Designer is software developed by DINA.
- The user application, instruction manual, Designer and all other documents can be stored on a memory medium, if a central module with an USB interface is used.
- The Medium is to use as a drive.
- The used connection cable with COM PORT interface is V24 (1:1). Pins 2, 3 and 5 are only important.
  
- Remark
  - The function devices are tested safe and certificated as a part of the firmware.
  - A modification of the certified function devices as part of the firmware is excluded.
  
- Behaviour with errors
  - Output O1 at the central module is switching off.
  - Correction Inspection of the wiring and assembly
  - Switching off and on of the power clears the errors. See also diagnostics tool at the Designer



#### 4 Mounting

- A central module is necessary in an Application.
- The number of other modules is breath-responsive.
- The central module is always left in the rack.
- The field bus is in the next slot.
- The data interface is separately right mounted if ZMB, ZMT or ZMR are used.
- The data interface and the field bus are integrated at the same module if a field bus is used.
- The relay module DNSL-KM can be used only with the DNSL-ZMR and must be placed at the right side.
- All other modules may be placed in any order

DNSL-ZMR	DNSL-EC	DNSL-IN	DNSL-IO	Free	DNSL-DS	DNSL-DR
----------	---------	---------	---------	------	---------	---------

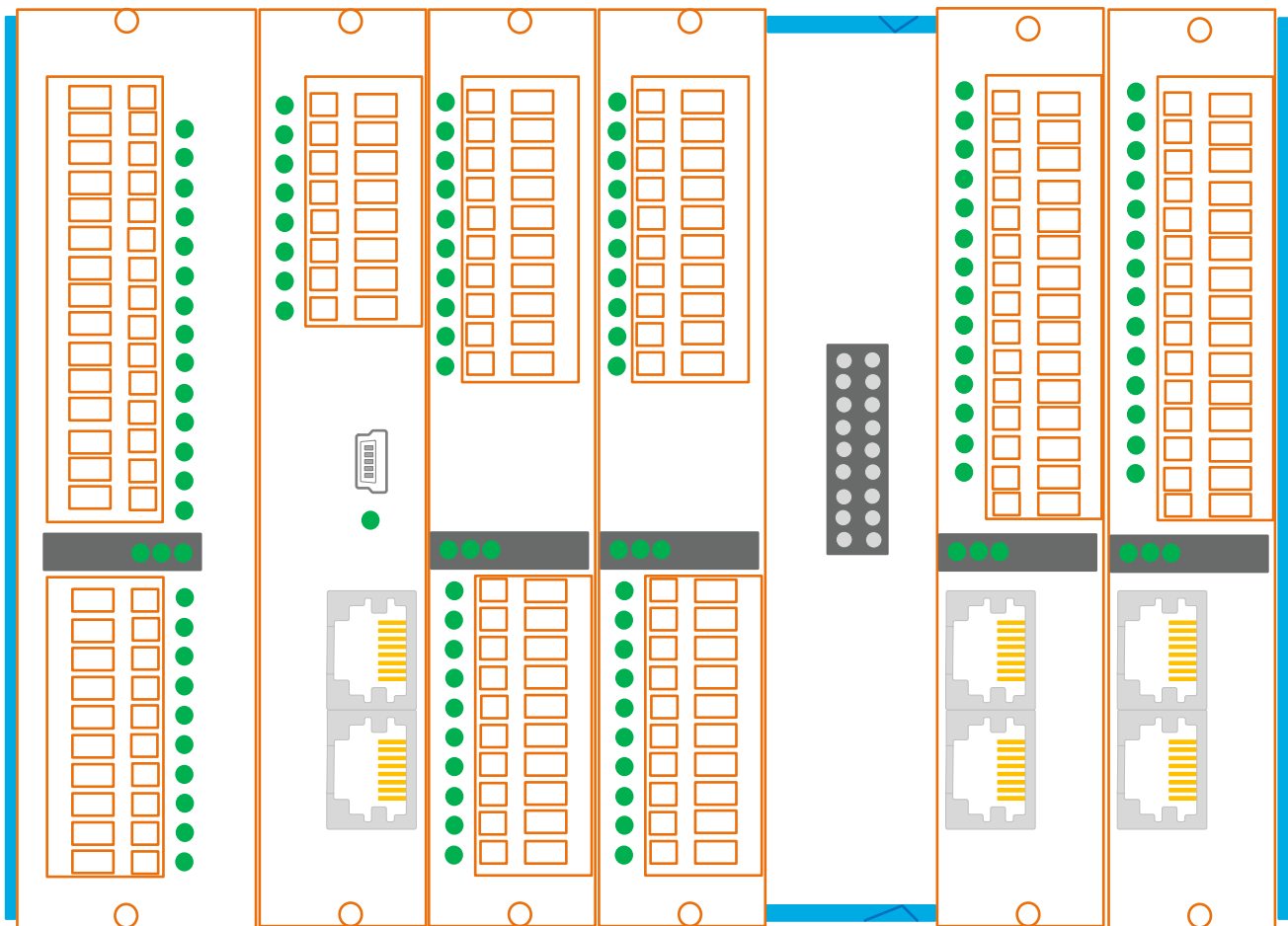

5 Central modules

DNSL-	ID-No.:	ID-No.:	Terminals	Description
	all		A1/ A2	Power supply terminals 24V DC for all modules in the application
	all		I1-I6	Safe digital inputs for safety functions
ZMB ZMR	24ZB40 24ZR40	24ZB40 24ZR40	I11-I20	Safe digital inputs for safety functions
ZMT	24ZT40	24ZT40	I11-I15	Safe digital inputs for safety functions
ZMT	24ZT40	24ZT40	I16-I20	Safe inputs for shut down mat Co. Mayser type TS/W1 and TS/ BK1
ZMB ZMR ZMT	24ZB40 24ZR40 24ZT40	24ZB40 24ZR40 24ZT40	1: I11, I12 2: I13, I14	2 safe standstill and speed monitoring using sensors with 24V signals
ZMA	24ZA20	24ZA30	UR,UA,0V	Connector for potentiometer
	all		O1	Semi-conductor output, system OK
ZM ZMR	24ZM20 24ZR40	24ZM30 24ZR40	O2-O5 O6, O7	Safe Semi-conductor output Safe Semi-conductor output for clock or switch outputs
ZMA ZMK ZMB ZMT	24ZA20 24ZK20 24ZB40 24ZT40	24ZA30 24ZK30 24ZB40 24ZT40	O2, O3	Safe Semi-conductor output
ZMB ZMT ZMK	24ZB40 24ZT40 24ZK20	24ZB40 24ZT40 24ZK30	13/14 24/24	Safe contact outputs
CP	24CP40			V24 interface for DNSL-ZMB, ZMR und ZMZ for data transfer
UP		24UP4		USB interface for DNSL-ZMB, ZMR und ZMZ for data transfer
KM	40KM01		O1-O4 13/14 - 83/84	Outputs for aiagnostics Safe contact outputs every with 2 contacts

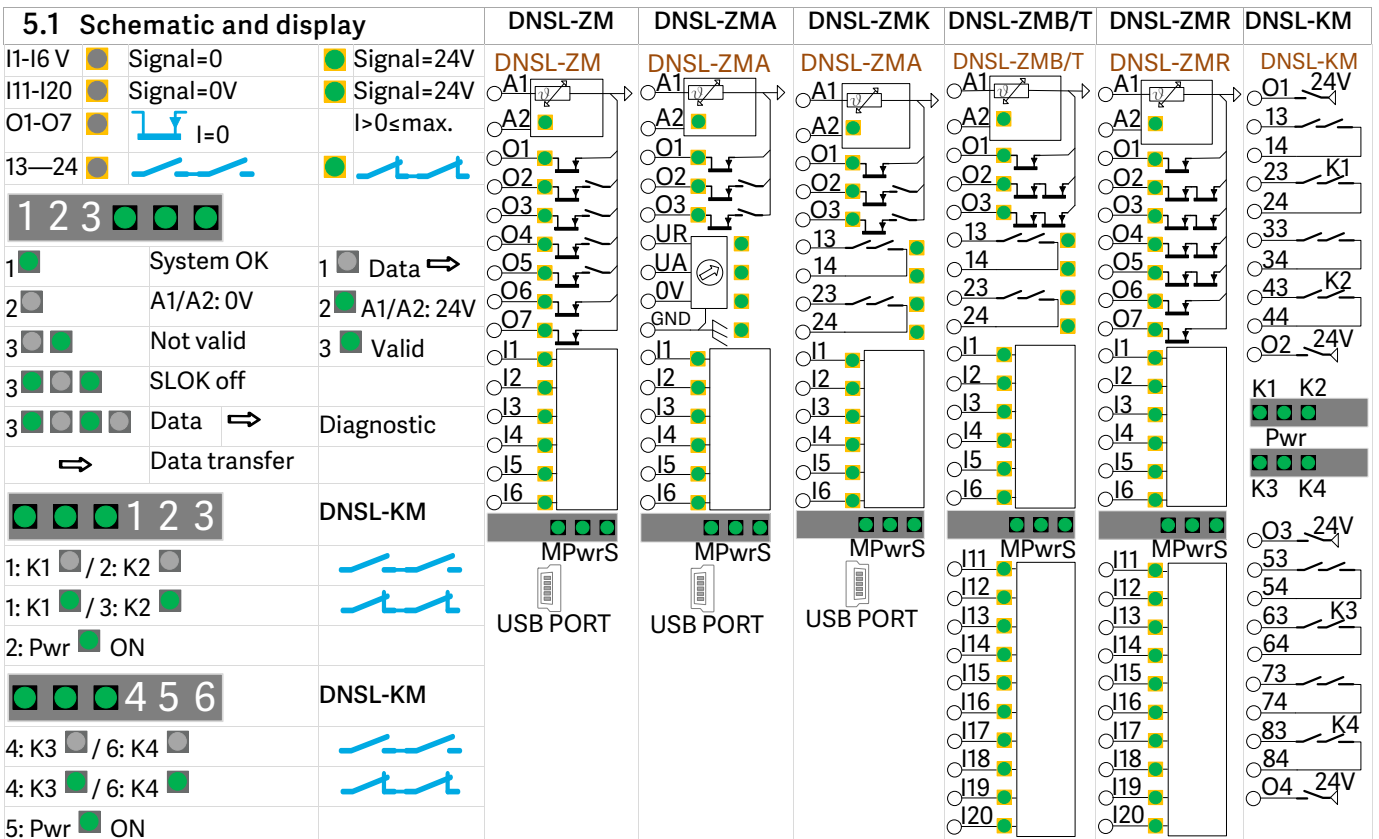

### 5.2 Front view of the central modules

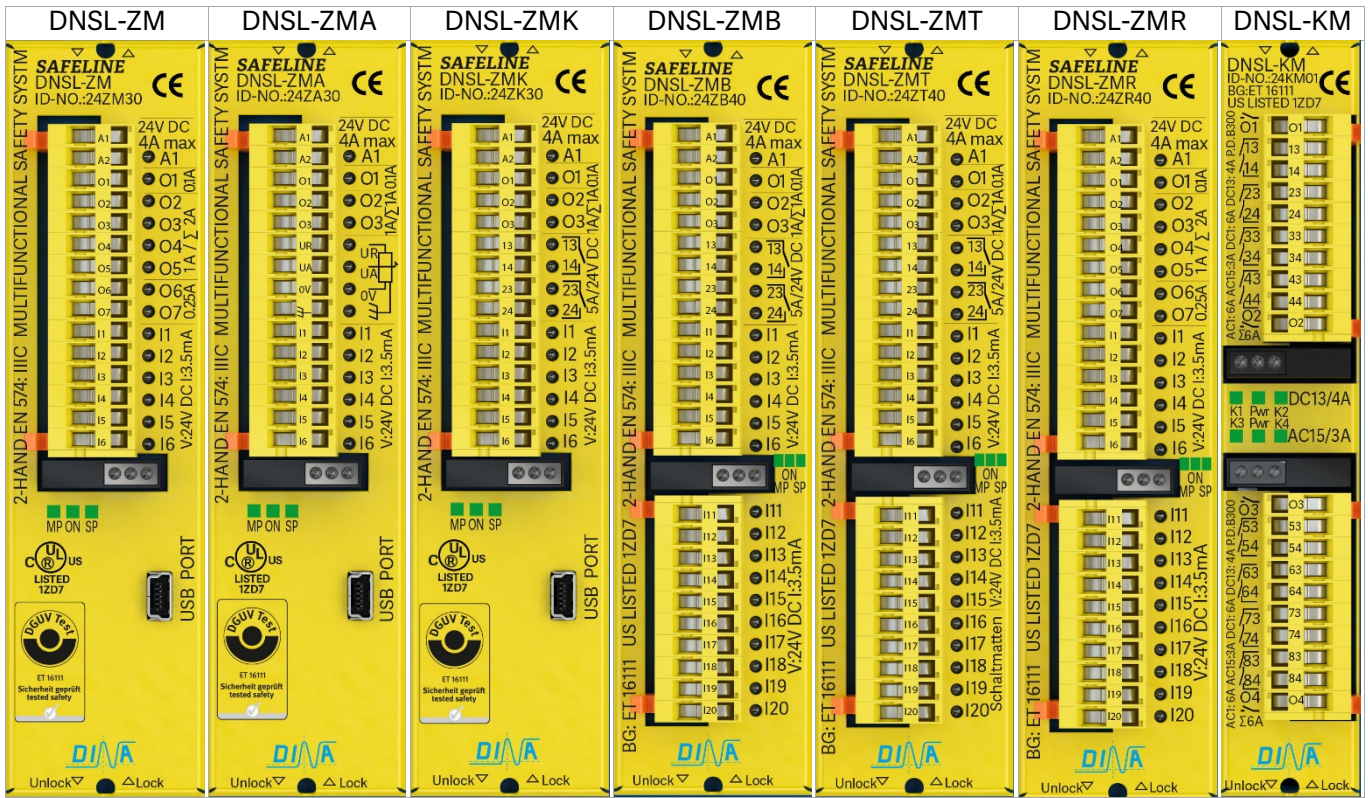

### 6 Field busses and interfaces

- The field busses are for data transfer between SAFELINE and the field bus master.
- The field bus is also deliverable with 8 safe inputs for different safety functions.
- The power supply for the field bus is ensured via the terminal inputs A1 and A2 at the central module.
- The data transfer interface is available separate or with integrated field bus COM PORT (DNSL-CP) and USP PORT (DNSL-UP) are available.
- These are for the central modules DNSL-ZMB/ ZMR and ZMT
- DNSL-ZM, ZMA and ZMK have the interface on board.

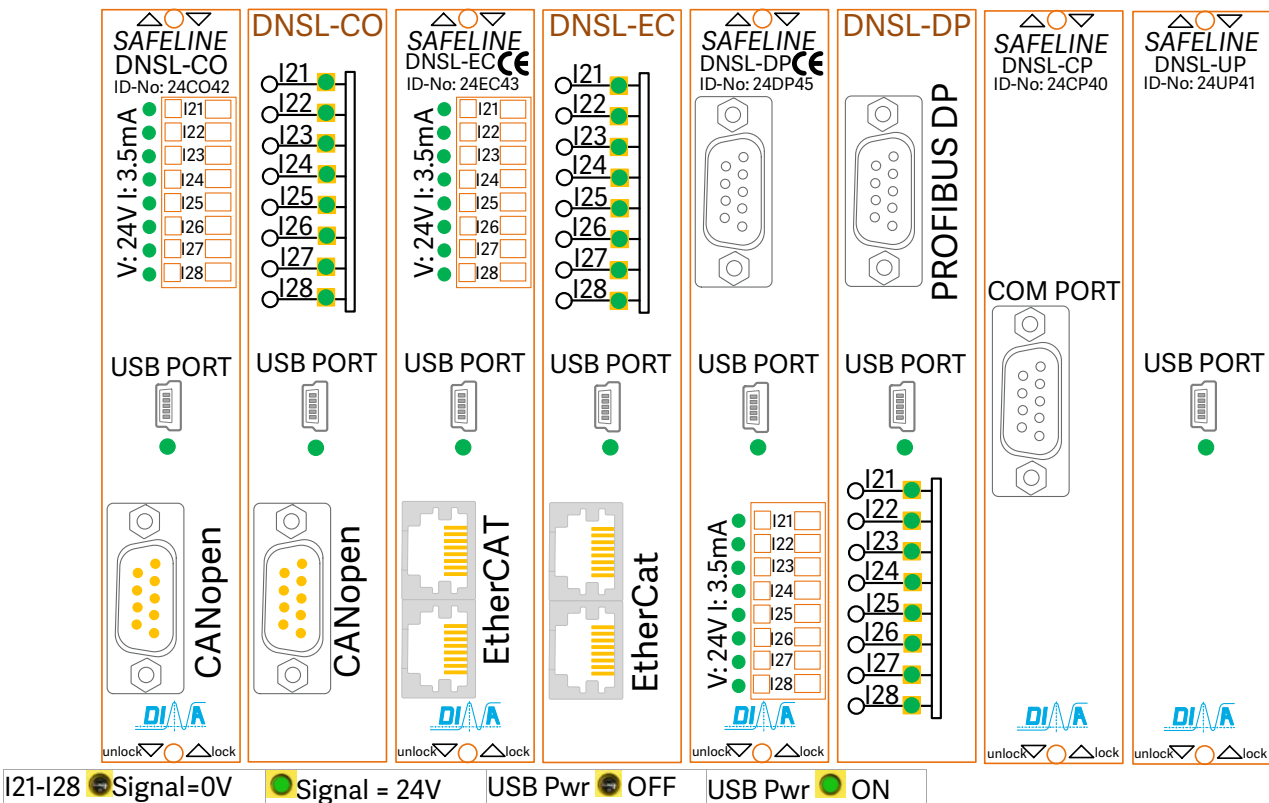

### 7 Standstill and speed monitoring

DNSL-	ID-No.:	Terminals/ connectors	Description
	all	B11-B18	Safe digital inputs for safety functions
	all	P1, P2	Terminal for 24V DC to supply the outputs
DS	24DS07	A, A/, B, B/	2 safe monitoring for standstill, speed, position, direction and brake in different function modes Sin/cos or TTL measuring systems, HTL signals via HTL cable adapter
DR	24DR01		2 safe monitoring for standstill, speed, position, direction and brake in different function modes Resolver Measuring system
SI	24SI02	SSI interface	2 safe monitoring for standstill, speed, position, direction and brake in different function modes SSI interface Measuring system
DS/ SI		O1-O4	Semi-conductor outputs configurable as safe or clock outputs
DR		O1-O2	Semi-conductor outputs configurable as safe or clock outputs

#### 7.1 Schematic, display and front view

See also Designer instruction manual.

Display	DNSL-DS	DNSL-DR	DNSL-SI
B11-14/ B21-24 <input type="checkbox"/> Signal=0V <input type="checkbox"/> Signal=24V			
O1-O4 <input type="checkbox"/> I=0 <input type="checkbox"/> I>0 ≤ max.			
P1/P2 <input type="checkbox"/> 0V <input type="checkbox"/> 24V			
1  n < max. 1  n > max.			
Monitoring 1 2  Pwr: 0V 2  Pwr: 24V			
3  n < max. 3  n > max.			
Monitoring 2 1  3			
No encoder 1  3			
Encoder OK 1  3			

### 8 In-, output modules

DNSL-	ID-No.:	Terminals	Description
IN	24IN01	I1 - I8 / I21 - I28	Safe digital inputs for safety functions
IO	24IN01	I21 - I28	Safe digital inputs for safety functions
IO2	24IO02	I15 - I18/ I21 - I28	Safe digital inputs for safety functions
IO/ IO2		P1, P2	Terminal for 24V DC to supply the outputs
IN		O11, O12, O21, O22	Semi-conductor outputs configurable as safe or clock outputs
IO/ IO2		O21, O22	Semi-conductor outputs configurable as safe or clock outputs
IO		O11 - O18	Semi-conductor outputs configurable as 4 safe outputs
IO2		O11 - O14	Safe semi-conductor outputs

#### 8.1 Schematic, display and front view

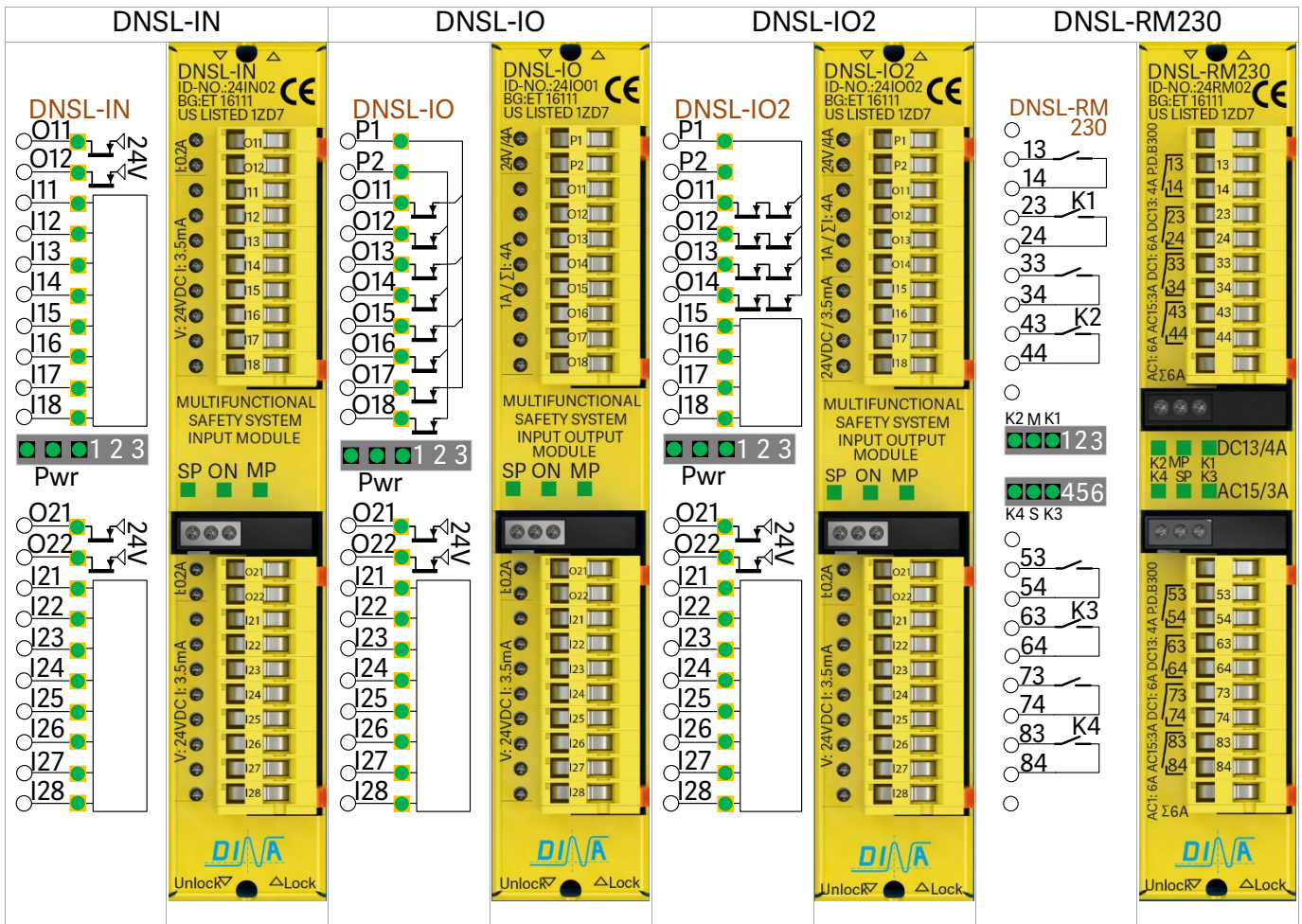

#### Display

DNS-IN/ DNSL-IO / DNSL-IO2		DNSL-RM230	
I11-18  Signal=0V	Signal=24V	1 2 3	2  MP OK
I21-28  Signal=0V	Signal=24V	1  3	K2/ K1
O11-18  I=0	I>0 ≤ max.	1  3	K2/ K1
O11-22  I=0	I>0 ≤ max.	4 5 6	5  SP OK
1 2 3	2  Pwr OFF/  Pwr ON	4  6	K4/ K3
1  3  CAN intern OFF	1  3  CAN intern OK	4  6	K4/ K3

### 9 Cascade using DNSL-CI and DNSL-CM

- Cascade installation is necessary if the SAFELINE Modules of an application have to be at different places of the construction to avoid wiring.
- Depending of the need functions the Modules will be mounted in different racks.
- In the basis unit is the central module and the cascade modules DNSL-CI if needed a fieldbus, function modules.
- In the periphery units PU the cascade module DNSL-CM is mounted for the central module and right of them the needed function modules FM.
- Maximal 14 FM are possible in one application.
- The connections between the units happen via RJ45 patch cables type DNRJ-45/45 with the necessary length.
- Serial or star shaped connection is possible.
- The power supply for the PU can be connected to CM. The DIP switches have to be adjusted EXTERN.
- With INTERN supplying is of the basis unit ( $I \leq 0.5A$ ).
- An address has to be assigned for every FM in the PUs. This happen via DIP switches at the rack circuit board.
- Every slot is equipped with a DIP switch. See graphic.

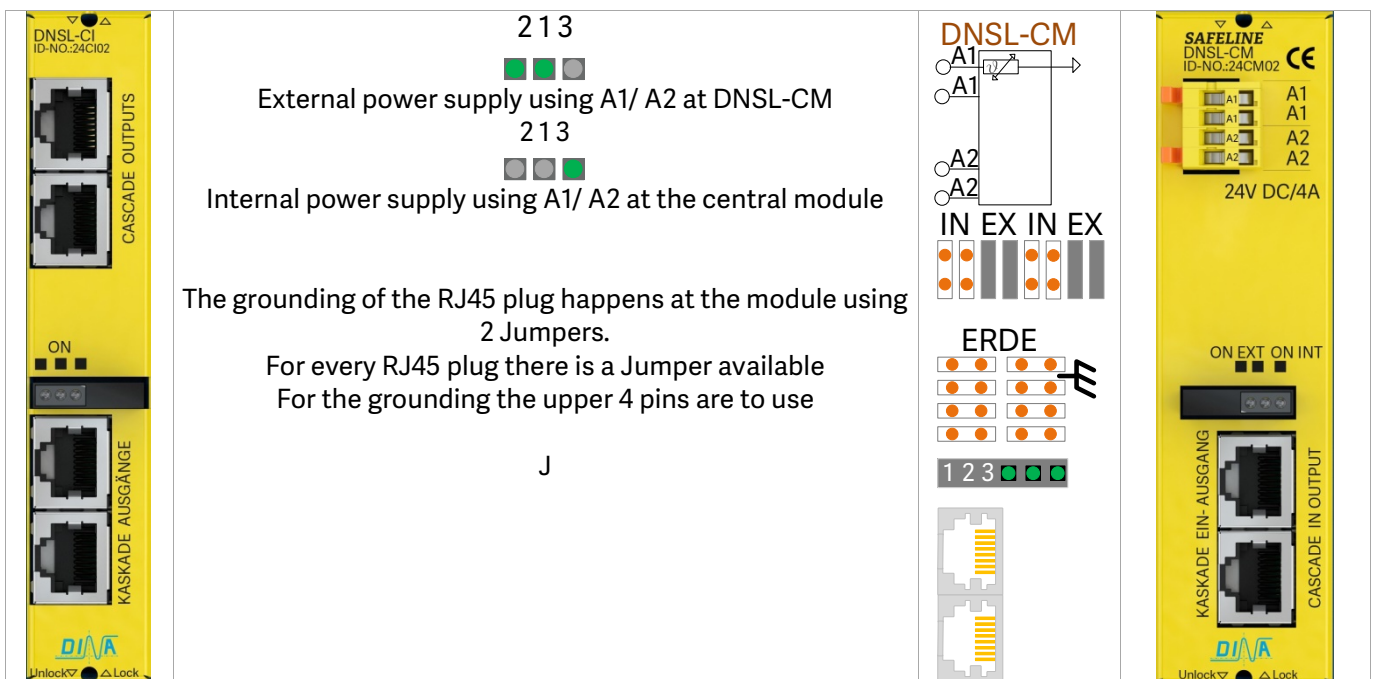

Serial cascade Star shape

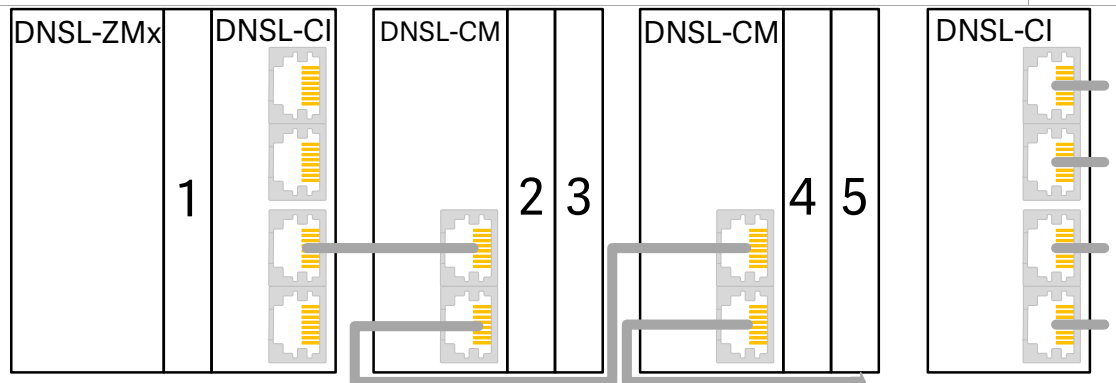

Addressing of the periphery units

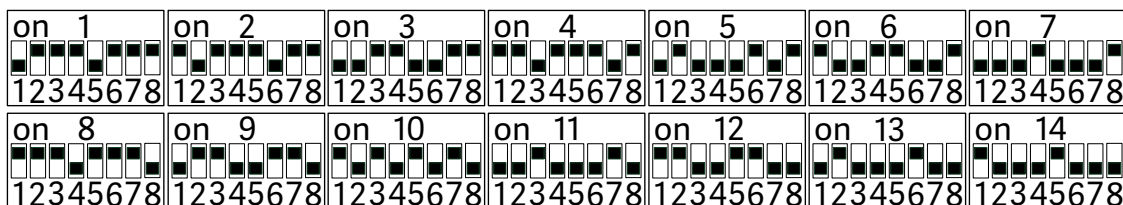

10 Networking using DNSL-NI

<ul style="list-style-type: none"> <li>• The data transfer happens via 4 RJ 45 sockets. The sockets can be local grounded via 4 internal jumpers.</li> <li>• The connection happens via Patch cable.</li> <li>• The connection can be starry or line shaped.</li> <li>• For every application a DNSL-NI is necessary.</li> <li>• A manual quit via the quit symbol at the Designer is necessary after an interrupt of the data transfer.</li> <li>• Signals of safety functions like emergency stop, protection cover, timer etc. can be transferred between the application using the data inputs and outputs.</li> <li>• The configuration happens in the Designer.</li> <li>• The schematic down left is a serial right a starry shaped networking</li> </ul>		
Serial shaped network	Star shape	

Designer Symbols



Input symbol	Output symbol	Quit Symbol

See also Designer instruction manual.

### 11 Inputs for safety functions

Modules	Inputs															
DNSL-ZM/ ZMA/ ZMK	I1	I2	I3	I4	I5	I6										
DNSL-ZMB/ ZMR/ ZMT	I1	I2	I3	I4	I5	I6	I11	I12	I13	I14	I15	I16	I17	I18	I19	I20
DNSL-DS / DR / SI	B11	B12	B13	B14	B21	B22	B23	B24								
DNSL-IN	I11	I12	I13	I14	I15	I16	I17	I18	I21	I22	I23	I24	I25	I26	I27	I28
DNSL-IO/ DNSL-FB									I21	I22	I23	I24	I25	I26	I27	I28
DNSL-IO2					I15	I16	I17	I18	I21	I22	I23	I24	I25	I26	I27	I28

#### 11.1 Safe Shutdown mat functions using I16 – I20 at DNSL-ZMT

Up to eight shutdown mats can be monitored.  
 After stepping on the mat the quit-function in the Designer can be activated.  
 The configuration will be done with the Designer.  
 Input value < min value: SM   
 Input value > min < max value: SM   
 Input value > max value: SM 

**Designer Symbol**

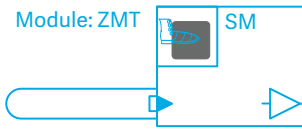

**Quit Symbol**

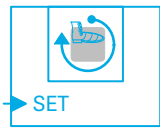

#### 11.2 Input for function mode switch (FMSS) at the central module

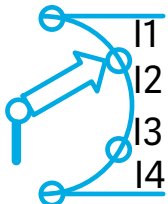
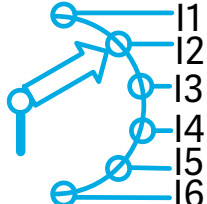
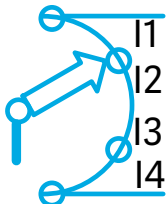
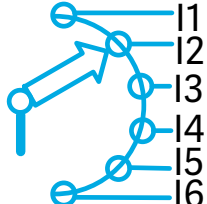
Function mode (FM)	FMSS with 4 positions						FMSS with 6 Positions											
3 Function modes	I1	I2	I3															
	FM1	FM2	FM3															
6 Function modes	I1	I2	I3	I4	I5	I6												
	FM1	FM2	FM3	FM4	FM5	FM6												

- Only one switching position has to be selected
- Error: None or more than one

Module: ZMR

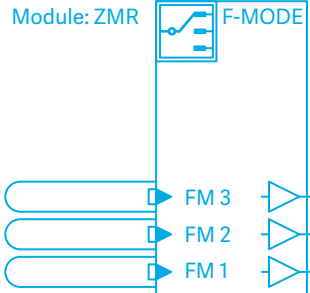

Module: ZMR

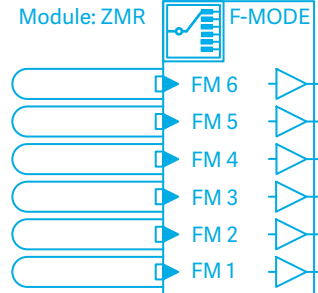

#### 11.3 Input for Tow-Hand functions according to EN 574: Type IIIC

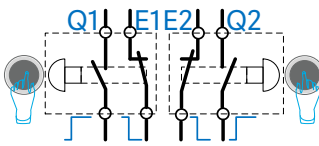
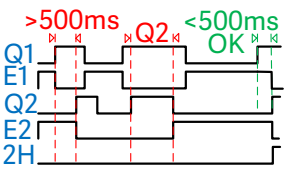
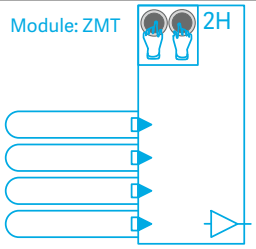
Modules	Inputs				Control	Diagram	Designer Symbol
	E1	Q1	E2	Q2			<p>Module: ZMT</p> 
DNSL-ZM/ ZMA	I1	I2	I3	I4			
DNSL-ZMK/ ZMB	I1	I2	I3	I4			
DNSL-ZMR/ ZMT	I1	I2	I3	I4			
DNSL-DS / DR	B11	B12	B13	B14			
DNSL-IN	I11	I12	I13	I14			
DNSL-IO/ IO2	I21	I22	I23	I24			

Start keys have to be activated during 500ms



### 11.4 Eingänge für Sicherheitskreise (SK) mit manuellem Quitt

Safety circuit (SC) / input name (E/Q) / Input (I/B)

	SK1			SK2			SK3			SK4			SK5		
Modules	E11	E12	Q1	E21	E22	Q2	E31	E32	Q3	E41	E42	Q4	E51	E52	Q5
DNSL-ZM/ ZMA/ ZMK	I1	I2	I3	I4	I5	I6									
DNSL-ZMB/ ZMR/ ZMT	I1	I2	I3	I4	I5	I6	I11	I12	I13	I15	I16	I17	I18	I19	I20
DNSL-DS / DR	B11	B12	B13	B21	B22	B23									
DNSL-IN	I11	I12	I13	I15	I16	I17	I21	I22	I23	I25	I26	I27			
DNSL-IO/ IO2							I21	I22	I23	I25	I26	I27			

- The control of the safety circuit happens parallel static, parallel using clock or static antivalent.
- Start edge Qt is configurable only at the central module. See Designer
- Start edge is constant (1s) at the function modules

#### Emergency stop

Control	Static parallel	Clock	Control	Antivalent: central module only
<b>Not-Halt</b>  E11 E12 Quit Q1	 Ablaufdiagramm E1 E2 Q SK	 Ablaufdiagramm E31 E32 Q3 SK	 Ablaufdiagramm E21 E22 Q2 SK	
<b>Permission</b>  E1 E2 Q1	 Diagram E1 E2 Q1 SK	 Diagram E1 E2 Q1 SK	 Diagram E1 E2 Q1 SK	
<b>Safe cover</b>  11 12 21 22 E1 E2 Q1	 Diagram E11 E12 Q1 SK	 Diagram E11 E12 Q1 SK	 Diagram E11 E12 Q1 SK	

Clock: see SAFELINE outputs for clock.

### 11.5 Inputs for safety circuit without quit input

8 safety circuits are possible.  
 At the Designer can be selected with or without quit.  
 Mixed is possible

Safety circuit (SC) / input name (E) / Input (I)

Modul	SK1		SK2		SK3		SK4		SK5		SK6		SK7		SK8	
	E11	E12	E21	E22	E31	E32	E41	E42	E51	E52	E61	E62	E71	E72	E81	E82
DNSL-IN	I11	I12	I13	I14	I15	I16	I17	I18	I21	I22	I23	I24	I25	I26	I27	I28

### 11.6 Quit for safety circuits (SC)

Central modules manual	Function modules
<ul style="list-style-type: none"> <li>Quit via quit-terminal, RTDS symbol or FBI7 at fieldbus</li> <li>Quit signal change , independent from source</li> <li>Quit-time Qt is selectable 0, 1, 3 and 5S</li> <li>FBI7 is active, FBI7 as follow to use: SK1: FBI7.1, SK2: FBI7.2, SK3: FBI7.3, SK4: FBI7.4, SK5: FBI7.5</li> <li>Central module automatic</li> <li>Quit signal is constant on, not necessary if "Off" selected.</li> <li>Terminal is free for another using</li> </ul>	<ul style="list-style-type: none"> <li>Quit is only possible via the quit-terminals.</li> <li>Signal change is needed . Qt is fixed at 1s.</li> <li>Automatic: quit signal constantly on</li> <li>No quit-signal: select automatic, quit-terminal at 24V.</li> <li>Protection cover: connect quit-signal to quit-terminal and select automatic.</li> </ul>

SLOK SK

- The function is only important if SC1 via I1-I3 or SC2 via I4-I6 at the central module is used as an emergency stop.
- With an external or internal error an emergency stop will be generated by SAFELINE.
- During the SLOK time SAFELINE works normally.
- After all outputs will be turned off. The plant stops.
- The SLOK Delay time has to be selected such as long, that the plant will be stopped safety.

2K OFF: SC off/on is not need.  2K OFF: SC off/on is need

## 12 Standstill and speed monitoring

### 12.1 Standstill and speed monitoring at DNSL-ZMB/ ZMR/ ZMT

- 2 safe monitoring for standstill and motion in different function modes for 2 axles
- Two sensors for every monitoring are required
- During standstill one sensor is active (24V signal).
- Sensors are constantly monitored

Sensor mounting	Sensor signals	Function modes	Monitoring 1 and 2
		MT: Non monitored automatic function mode F13: Monitored automatic function mode F12: Monitored semi-automatic function mode F11: Monitored tool setting function mode	

### 12.2 Requirement at Proximity sensors

- Two sensors for every monitoring
- At the cogwheel one sensor opposite to cog other to gap
- During standstill at least one sensor has 24V signal.

### 12.3 Standstill and speed monitoring using DNSL-DS

- Zwei Überwachungen sind möglich.
- Für jede Überwachung ist ein inkrementelles Messsystem erforderlich, Sinus/ Kosinus 1Vss oder TTL Signale ( $\leq 500$  KHz).
- Stillstand, Position, Richtung, Bremse und Drehzahl in diversen Betriebsarten können überwacht werden.
- Für Bremsüberwachung siehe Designer Betriebsanleitung.

Encoder connection	Sin/ Cos 1Vss or TTL 1-5V encoder, $\leq 500$ KHz	Monitoring 1 and 2	Function
<p>RJ45 female</p>	<p>MT: Non monitored automatic function mode F13: Monitored automatic function mode F12: Monitored semi-automatic function mode F11: Monitored tool setting function mode</p>		<p>Brake Standstill Speed Direction</p>

### 12.4 Requirement at the Measuring system

Sin / Cos or TTL measuring system	HTL measuring system
<ul style="list-style-type: none"> <li>• Amplitude 1Vpp sinus / cosine or TTL, Frequency <math>\leq 500</math>KHz</li> <li>• 2 tracks, 90° phase offset, per track 2 signals, 180° phase shifted</li> <li>• A direct connection between motion monitoring and measuring system is required</li> </ul>	<ul style="list-style-type: none"> <li>• Amplitude 18 to 26V square wave, Frequency <math>\leq 500</math>KHz</li> <li>• 2 tracks, 90° phase offset, per track 2 signals, 180° phase shifted</li> <li>• A direct wire connection between motion monitoring and measuring system is required.</li> <li>• System without negated signals is possible.</li> </ul>

### 12.5 Standstill and speed monitoring using 2 Sensors for measuring system

- For every monitoring 2 PNP sensors with antivalent signals.
- The sensors signals have to be connected to the RJ45 plugs the cable adapters type DNRJ45 HTL-SL.
- For direction monitoring a time difference between the impulse edges of both signals for the whole speed range.
- Value of time difference and duty cycle are not relevant.
- After power-on The LR-signal is indefinite.
- Usage of sensors with one output is possible. Here is a Monitoring of the direction not possible

### 12.6 Standstill and speed monitoring using DNSL-DR

- 2 safe monitoring for Standstill, position; direction; break and speed in different function modes
- For every monitoring a Resolver measuring system (1–10V /  $\leq 1200$ Hz) is necessary.

Encoder connection	1-10V, 1 – 10V Resolver encoder, $\leq 1200$ Hz	Monitoring 1 and 2	Function
<p>RJ45 female</p>	<p>MT: Non monitored automatic function mode F13: Monitored automatic function mode F12: Monitored semi-automatic function mode F11: Monitored tool setting function mode</p>		<p>Brake Standstill Speed Direction</p>

#### Adjustment of the Resolver amplitude

Amplitude	1-2Vss	2-4Vss	4-8Vss	8-10Vss
Adjustment				

### 12.7 Standstill and speed monitoring using DNSL-SI

- 2 safe monitoring for Standstill, position; direction; break and speed in different function modes
- For every monitoring a SSI interface measuring system is necessary.

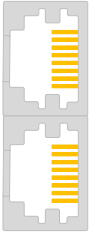
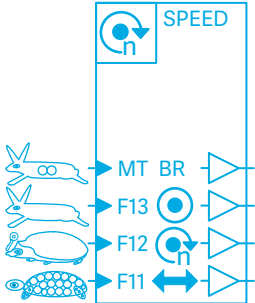
Encoder connection	SSI interface	Monitoring 1 and 2	Function
 RJ45 female	MT: Non monitored automatic function mode F13: Monitored automatic function mode F12: Monitored semi-automatic function mode F11: Monitored tool setting function mode		Brake Standstill Speed Direction

### 12.8 Quit of the speed monitoring



- After a quit using the RTDS-symbol the output (SSM) has a High-signal if the measurement system is error-free.
- SSM has Low-signal during movement if no function mode is selected via F--or MT-.
- Selection of function modes happens via hardware inputs.
- To control the terminals permission-switches can be used as inching mode contact, permission key contact or safety cover contact

Priority: MTx > Fx3 > Fx2 > Fx1 > standstill

### 12.9 Brake monitoring with DNSL-DS, DR and SI

- The output BR (SAR) at the symbol is to use for the ramp monitoring of an axle.
- The speed of the drives will be recorded every 100ms during 500ms. After the first value will be overwritten.
- During standstill, constant speed and acceleration the virtual output is LOW.
- It changes to HIGH if the speed is reduced  $\leq 5\%$  during 500ms.
- The shortest reaction time is 100ms.
- Hardware output or virtual input can be triggered with this output

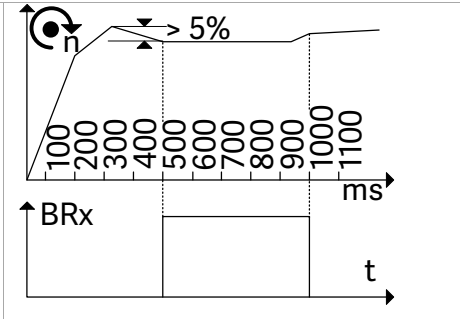

### 12.10 Direction monitoring with DNSL-DS, DR and SI

- During standstill and while sinus is advanced, the virtual output (SDI) has signal High.
- If cosine is advanced signal is Low.
- The preferred direction can be selected via hardware inputs and logic elements.

### 12.11 DNCO Function to monitor the Peripheral speed

Modules	8 Speed			16 Speed				48 Speed				
DNSL-ZMx	I1	I2	I3	I1	I2	I3	I4	I1	I2	I3	I4	I5
DNSL-DS/ DR	B11	B12	B13	B11	B12	B13	B14	B11	B12	B13	B14	B21
DNSL-IN	I11	I12	I13	I11	I12	I13	I14	I11	I12	I13	I14	I15
DNSL-IO/ IO2	I21	I22	I23	I21	I22	I23	I24	I21	I22	I23	I24	I25

- The DNCO function enables the monitoring up to 2 x 48 different speeds.
- 2 drives can be monitored.
- Setting of 8, 16 or 48 speeds is available.
- Up listed inputs are to set the speeds.
- DNCO1 unit can be used to set the inputs.
- The configuration happens at the Designer.

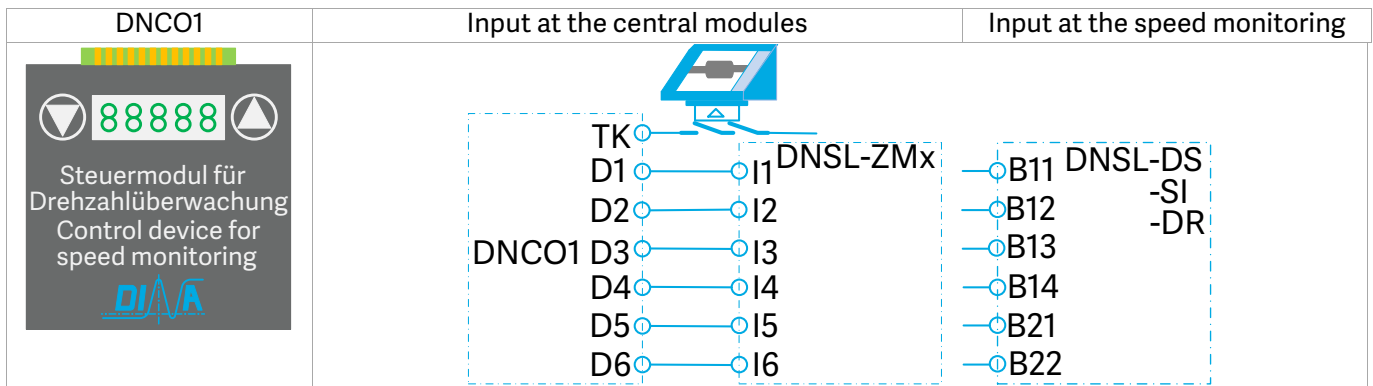

### 12.12 Analogue inputs for DNCO-function at DNSL-ZMA

- The voltage analogue input UA enables the selection of up to 8 different speeds.
- The value of these motions can be entered in the table DNCO1 at the Designer via the teach function automatically.
- The monitoring happens at DNSL-DS or DR.

## 13 Cable adapter

The DNDA is used as an interconnection between the drive measuring system and the speed monitoring system. There are different versions of cable adapter available. See cable adapter instruction manual.

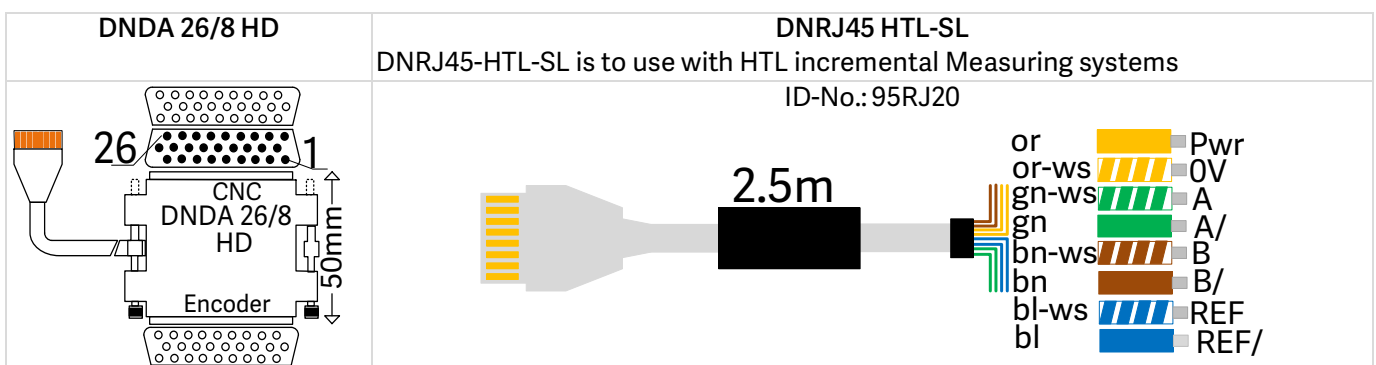
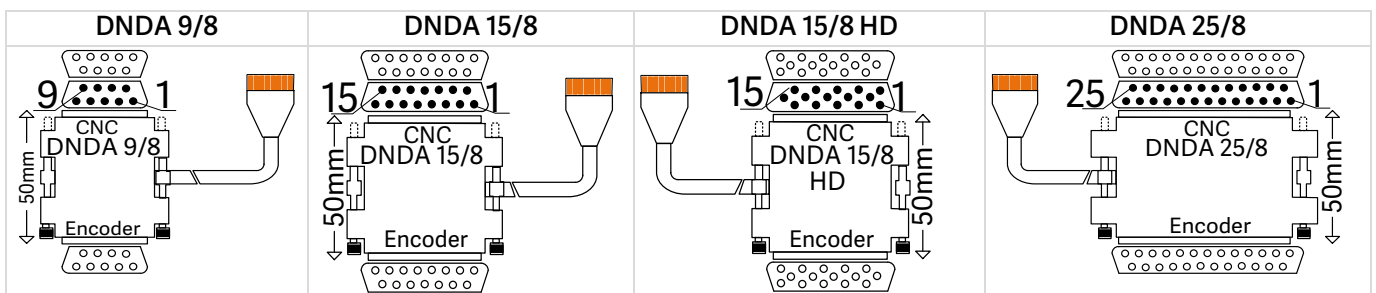

14 Data in- and outputs at the field bus

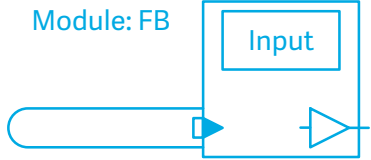
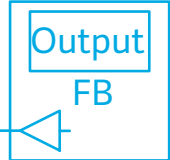
Input data		Designer Symbol		Outputs data		Designer Symbol
FBI1.1 - FBI1.8 FBI2.1 - FBI2.8 FBI3.1 - FBI3.8 FBI4.1 - FBI4.8	IN		Out	FBO1.1 - FBO1.8 FBO2.1 - FBO2.8 FBO3.1 - FBO3.8 FBO4.1 - FBO4.8 FBO5.1 - FBO5.8 FBO6.1 - FBO6.8 FBO7.1 - FBO7.8 FBO8.1 - FBO8.8	Out	

15 Outputs at SAFELINE

DNSL-		I: A	Performance Level	Beschreibung
ZM/ ZMA/ ZMK ZMB/ ZMR/ ZMT	O1	0.1A	PLc	1 output, System OK
ZM	O2-05	1A / $\Sigma$ 2A	PLe	4 safe outputs,
ZM/ ZMR	O6/ O7	0.25A	PLc / PLe <sup>(2)</sup>	2 outputs, 2 clock or 1 safe output
ZMA/ ZMK	O2/ O3	1A / $\Sigma$ 1A	PLe	2 safe outputs
ZMB	O2/ O3	1A / $\Sigma$ 1A	PLe	2 safe outputs
ZMB/ ZMK/ ZMT	13 14 23 24	$\geq 10\text{mA} \leq 6\text{A}$ DC13: 24V/5A	PLe	2 output with 2 safe contacts
ZMR	O2-05	1A / $\Sigma$ 2A	PLe	4 safe outputs
KM	13/ 23 14/ 24 33/ 43 34/ 44 53/ 63 54/ 64 73/ 83 74/ 84 O1-04	$\geq 10\text{mA} \leq 6\text{A}$ 13 – 44: $\Sigma 6\text{A}$ 53 - 84: $\Sigma 6\text{A}$ DC13: 24V/ 5A 0.1A	PLe	4 outputs every with 2 safe contact
			PLc	4 diagnostics contact outputs
DS / SI	O1-04	1A, $\Sigma 2\text{A}$	PLc / PLe	4 outputs, 4 clock or 2 safe outputs
DR	O1/O2	1A, $\Sigma 1\text{A}$	PLc / PLe	2 outputs, 2 clock or 1 safe outputs
IN	O11/ 12/ 21/ 22	0.25A	PLc / PLe	4 outputs, 4 clock or 2 safe outputs
IO	O11/ 13/ 15/ 17 O12/ 14/ 16/ 18	1A, $\Sigma 4\text{A}$	PLc / PLe	8 outputs or 4 safe outputs
IO/ IO2	O21/22	0.25A	PLc / PLe	2 outputs, 2 clock or 1 safe output
IO2	O11-O14	2A / $\Sigma 4\text{A}$	PLe	4 safe outputs
RM230	13 14/ 23 24 33 34/ 43 44 53 54/ 63 64 73 74/ 83 84 13 14/ 33 34 23 24/ 43 44 53 54/ 73 74 63 64/ 83 84	$\geq 10\text{mA} \leq 6\text{A}$ DC13: 24V/5A AC15: 230V/3A $\Sigma 6\text{A}$	PLc	4 Ausgänge je 2 NO Kontakte
			PLe	Konfiguration als 2 Ausgänge je 2 sichere NO Kontakten

- The outputs can be used for safety relevant control functions as emergency stop, protection cover, permission, drives authorization, net authorization, to unlock of protection cover and other safety functions.
- All semi-conductor outputs are positive switching.

Designer Symbol

Safe output	Clock output	2 Safe contacts	8 Safe contacts KM	8 contacts RM
		Contact ZMB 13 14 23 24	Contact KM 13/23/33/43 14/24/34/44 53/63/73/83 54/64/74/84	Contact RM 13/53 14/54 23/63 24/64 33/73 34/74 43/83 44/84

16 General technical data

16.1 Electrical characteristics

Operation voltage $U_B$	24V DC on A1/ A2 central module for a complete unit			
Margins $U_B$	85 - 110%			
Ripple $U_B$	Max. 10 %			
Power consumption in W	Central modules 2,9	Field busses 1,0	DNSL-KM 4,8	Speed monitoring 2,5
	DNSL-IO/ IO2 2,2	DNSL-IN 1,7	DNSL-NI 1,0	DNSL-RM230 4,8
Input current at A1 of the central modules	$\leq 4A$ / internal fuse: 6A			
Operating temperature	-10 +60°C			
Storage temperature	-40 +85°C			
Vibration resistance 3 axis	Sinus 10–55Hz, 0,35mm, 10 cycles, 1 octave /min			
Max. cable cross section	1 x 1,0mm <sup>2</sup> , spring load clamps, pluggable			
Housing material	Steel sheet galvanized, powder coated			
Protection class	Installation in a closed cabinet with $\geq$ <b>IP 54</b>			
Voltage at the inputs	24V DC -15%, + 10%			
Input current consumption	Max. 3,5mA			
Input voltage at P1 and P2 with DNSL-DS, DR, IO, IO2	24V DC -15% + 10%			
Input current at P1 and P2	$\leq 4A$			
Input frequency at I11-I14, O1 at central modules	$\leq 1200$ Hz			
Output voltage $U_R$ with DNSL-ZMA	15V against 0V terminal			
Input voltage $U_A$ with DNSL-ZMA	0 to 15V over 1K $\Omega$ potentiometer against 0V			

16.2 Semiconductor outputs at the central module

	alle	DNSL-ZM	ZMA, ZMK	DNSL-ZMR	ZMB, ZMT
Output design					
Performance Level as safe output	O1	O2 – O5	O6, O7	O2 – O5	O6, O7
Output	0,1A	1A	0,25	1A	0,25
Switch and continuous current $\Omega$ / L		2A	0,4A	1A	2A
Sum of the switch and continuous current $\Omega$ / L	1mA	10mA	1mA	10mA	1mA
Minimal switch current		$\geq 2 \times 10^6$		$\geq 2 \times 10^6$	
Mechanical contact life (switching cycles)		$\geq 8 \times 10^5$		$\geq 8 \times 10^5$	
Electrical life 1A load $\Omega$		$\geq 5 \times 10^5$		$\geq 5 \times 10^5$	
Electrical life 1A load L $\text{Cos}\phi = 0,4$ (cycle)		$\leq 10$ mS		$\leq 10$ mS	
Reaction time, drop out time		1800		1800	
		cycles/h		cycles/h	

16.3 Semiconductor outputs at the function modules

See also page 23.	DS	DR	IO	IO2	IN/ IO/IO2
Output design					
Output	O1-O4	O1, O2	O11-18	O11-O14	O11, 12, 21, 22
Switch and continuous current $\Omega$ / L	1A	1A	1A	2A	0,25A
Sum of the switch and continuous current $\Omega$ / L	2A	1A	4A	4A	0,4A
Minimal switch current	1mA	1mA	1mA	1mA	1mA





: Load voltage during wire break at terminal A2 depending of load current:

5mA	<4,5V	10mA	<2,5V	20mA	<1,0V	0,1A	<200mV
0,5A	<100mV	1A	<50mV	Rest current during short	<5 $\mu$ A		

All semiconductor outputs are short circuit and overload proof.  
A recovery diode is necessary for interference suppression of the output load for all semiconductor outputs.



### 16.4 Contact outputs at SAFELINE

	ZMB,ZMK, ZMT	RM 230	KM	
Output design				
Output	13/14, 23/24	13/14 – 83/84	13/14 – 83/84	O1-O4
Minimal switch current	10mA	10mA	10mA	10mA
Switching capacity according to DIN EN 60947-4-1/ EN 60947-5-1	DC1: 24V/ 6A DC13: 24V/ 5A 0,1Hz	DC1: 24V/ 6A DC13: 24V/ 5A 0,1Hz	DC1: 24V/ 6A DC13: 24V/ 5A 0,1Hz	
Switching capacity according to DIN EN 60947-4-1/ EN 60947-5-1		AC1:250V/ 6A AC15: 230V/ 3A	AC1:250V/ 6A AC15: 230V/ 3A	
Sum of the switch and continuous current	≤ 6A	13/14-43/44: ≤ 6A 53/54-83/84: ≤ 6A	13/14-43/44: ≤ 6A 53/54-83/84: ≤ 6A	0,4A
Electrical life <sup>(1)</sup> at DC13: 24V/ 1A	1x10 <sup>5</sup>	1x10 <sup>5</sup>	1x10 <sup>5</sup>	
Electrical life <sup>(1)</sup> at DC13: 24V/ 4A	4x10 <sup>4</sup>	4x10 <sup>4</sup>	4x10 <sup>4</sup>	
Electrical life <sup>(1)</sup> at AC15: 230V/ 1A		2x10 <sup>5</sup>	2x10 <sup>5</sup>	
Electrical life <sup>1)</sup> at AC15: 230V/ 4A		8x10 <sup>4</sup>	8x10 <sup>4</sup>	
Switch and continuous current Ω / L				0,1A
Mechanical contact life <sup>(1)</sup>	> 10 <sup>7</sup>	> 10 <sup>7</sup>	> 10 <sup>7</sup>	> 2X10 <sup>6</sup>
Maximal switching cycles at DC13: 5A	360 cycles/h	360 cycles/h	360 cycles/h	
Maximal switching cycles at AC15: 3A		360 cycles/h	360 cycles/h	
Contact fuse	6A slow	6A slow	6A slow	
Short circuit strength: Automat safety fuse	1000A SCPD 6A	200A/ B6 800A/ 6A gG	1000A SCPD 6A	
Rated insulation voltage		250V AC	250V AC	
Impulse withstand voltage		4KV	4KV	
Use in pollution degree 2 Environment.				
Reaction time, drop out time	10ms	10ms	10ms	10ms

### 16.5 Electrical life of the contact outputs

260 work days/ year, 8h work time/ day, switching voltage 24V DC

Modules	DNSL-ZMB, ZMK, ZMT: K1, K2					DNSL-RM, 13/14---83/84					Years
Load kind	DC1	DC13	DC1	DC13	DC1	DC1	DC13	DC1	DC13	DC1	
Switch current	1A	1A	4A	4A	6A	1A	1A	4A	4A	6A	
Switch cycle/h	1300	123	270	30	230	1300	123	270	30	230	5
	650	61	135	15	115	650	61	135	15	115	10
	325	30	67	8	58	325	30	67	8	58	20

Modules	DNSL-KM, 13/14---83/84					Years
Load kind	DC1	DC13	DC1	DC13	DC1	
Switch current	1A	1A	4A	4A	6A	
Switch cycle/h	1300	123	270	30	230	5
	650	61	135	15	115	10
	325	30	67	8	58	20

260 work days/ year, 8h work time/ day, switching voltage 230V AC

Modules	DNSL-ZMB, ZMK, ZMT: K1, K2					DNSL-RM, 13/14---83/84				Years
Load kind	AC1	AC15	AC1	AC15	AC15	AC1	AC15	AC1	AC15	
Switch current	Not possible					1A	1A	4A	3A	
Switch cycle/h						308	162	92	62	5
						154	154	81	46	10
	72	72	40	23	20					

Modules	DNSL-KM, 13/14---83/84				Years
Load kind	AC1	AC15	AC1	AC15	
Switch current	1A	1A	4A	3A	
Switch cycle/h	308	162	92	62	5
	154	154	81	46	10
	72	72	40	23	20

AC1: control of non or low inductive load, AC voltage  
 AC15: control of electro-magnetically load, AC voltage  
 DC1: control of non or low inductive load, DC voltage  
 DC13: control of electro-magnetically load, DC voltage

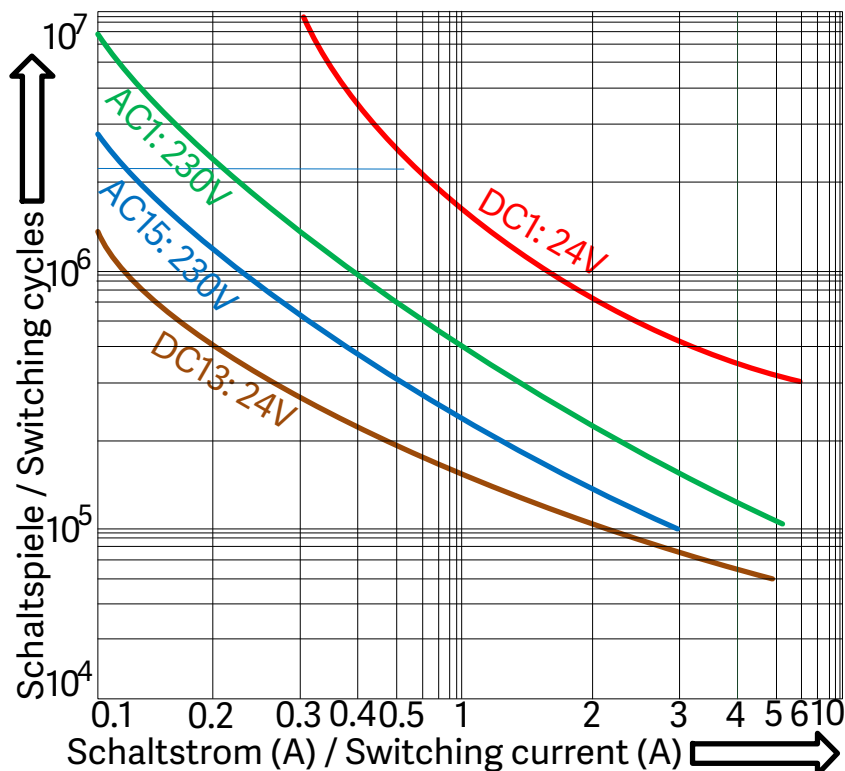

17 Dimension and installation

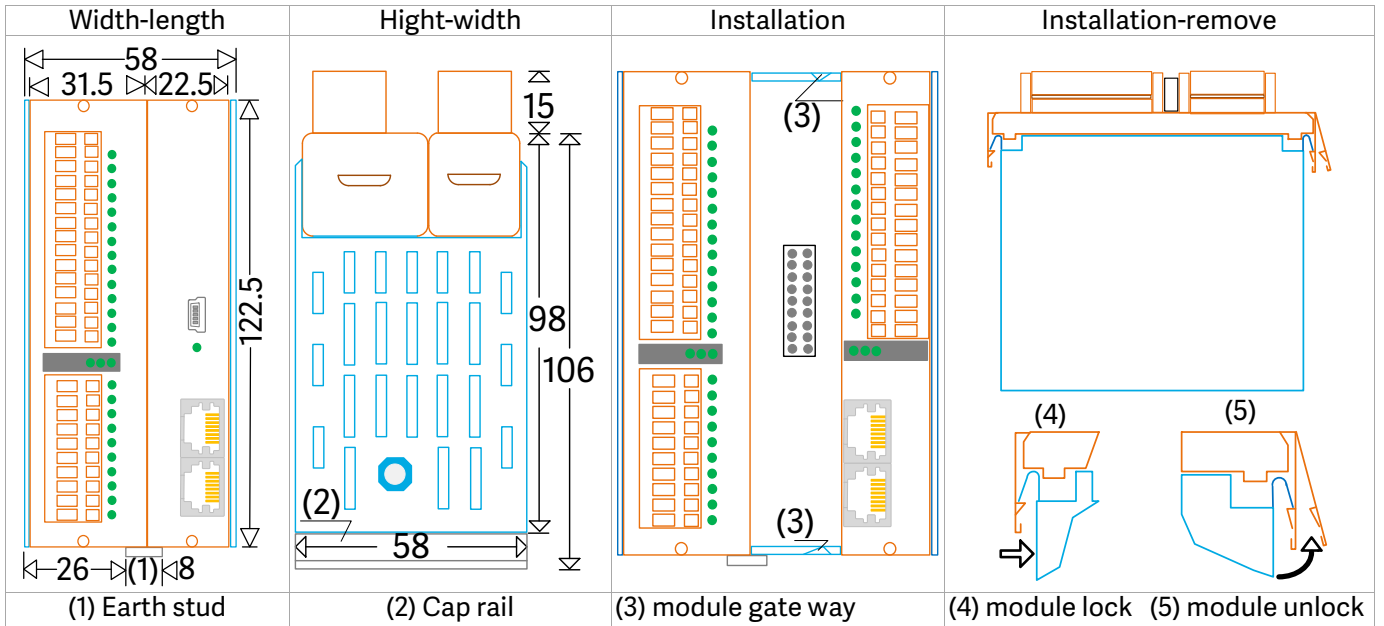

17.1 Rack variants

ZM, ZMA, ZMK, ZMB, ZMT	width	Modules	DNSL-ZMR + DNSL-KM	width	Modules
Rack	mm		Rack	mm	
DNSL-R2	58	ZM/ CM + FB			
DNSL-R3	81	ZM/ CM + FB + 1 FM	DNSL-R3-KM	81	ZM/ CM+FB+KM
DNSL-R5	125	ZM/ CM + FB + 3 FM	DNSL-R5-KM	125	ZM/ CM+FB+KM+2 FM
DNSL-R7	170	ZM/ CM + FB + 5 FM	DNSL-R7-KM	170	ZM/ CM+FB+KM+4 FM
DNSL-R9	215	ZM/ CM + FB + 7 FM	DNSL-R9-KM	215	ZM/ CM+FB+KM+6 FM
DNSL-R11	260	ZM/ CM + FB + 9 FM	DNSL-R11-KM	260	ZM/ CM+FB+KM+8 FM
DNSL-R13	305	ZM/ CM + FB + 11 FM	DNSL-R13-KM	305	ZM/ CM+FB+KM+10 FM
DNSL-R15	350	ZM/ CM + FB + 13 FM	DNSL-R15-KM	350	ZM/ CM+FB+KM+12 FM



we are safety.

DINA Elektronik GmbH  
Esslinger Str. 84  
D72649 Wolfschlugen  
Phone +49 7022 95 17 0  
Fax +49 7022 95 17 700  
[info@dina.de](mailto:info@dina.de)  
[www.dina.de](http://www.dina.de)