



# SERIE 59

## HIGH RESOLUTION HOLLOW SHAFT INCREMENTAL ENCODER FOR INDUSTRIAL APPLICATIONS

- Resolution up to 50.000 pulses per turn
- External diameter 58 mm
- Hollow shaft from  $\varnothing$  10 to 14 mm
- Protection class IP67 according to DIN EN 60529
- Shaft fixing through front or rear clamp
- Anti-rotation system through flexible flange, pin torque support or anti-turn stick
- Connection by cable (other cable length available) or industrial connector M12 or M23
- Female connector included



Optical Encoder	Incremental Encoder	High shaft load capacity	Vibration and shock resistant	IP67	Temperature range	Express Delivery

### Rear clamp

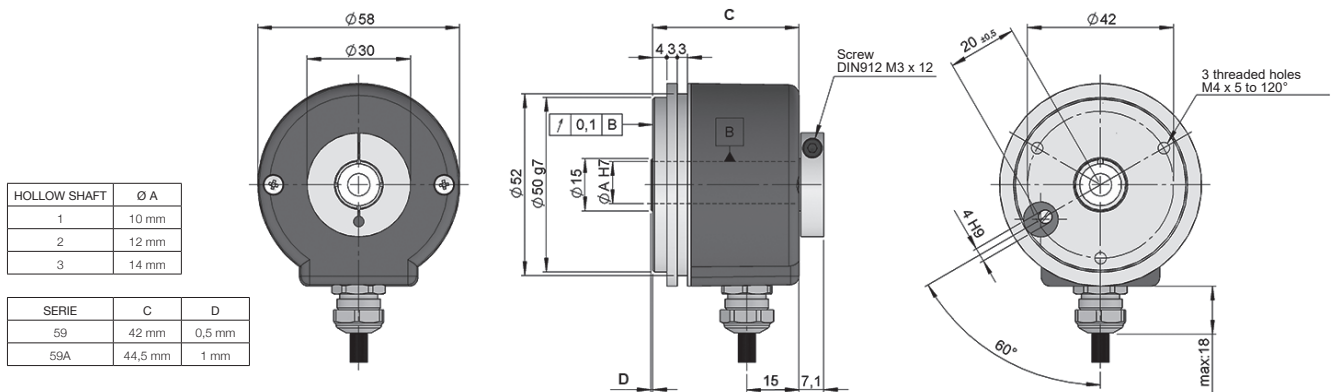

Drawing mechanical option type 1, hollow shaft type 2, connection type 1

### Frontal clamp

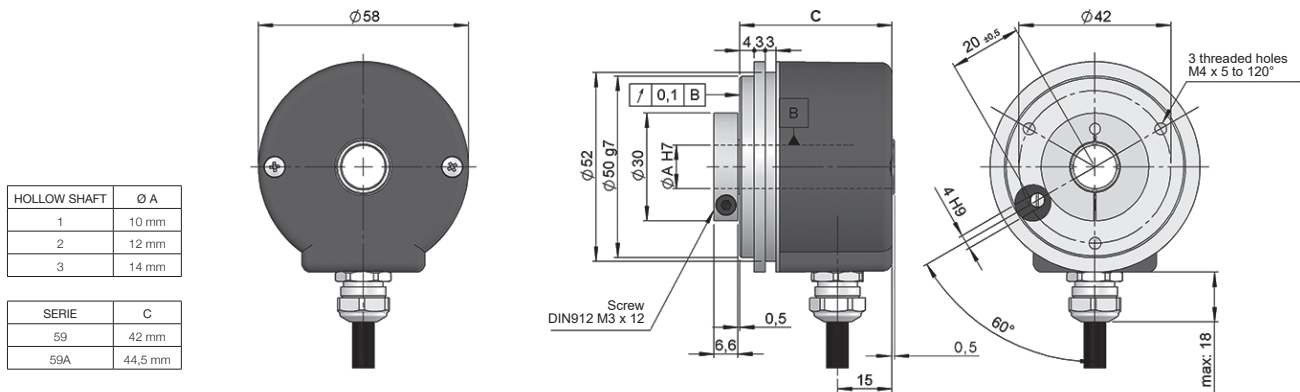

Drawing mechanical option type 2, hollow shaft type 2, connection type 1



# SERIE 59

## HIGH RESOLUTION HOLLOW SHAFT INCREMENTAL ENCODER FOR INDUSTRIAL APPLICATIONS

REFERENCE								Reference example: 59-21111-1024
Serie	Mechanical option	Hollow shaft	Output signals	Connection	Power Supply / Electronic output	Pulses number	Special customer	
<b>59/59A -</b>	<input type="checkbox"/>	<input type="checkbox"/>	<input type="checkbox"/>	<input type="checkbox"/>	<input type="checkbox"/> -	<input type="checkbox"/> <input type="checkbox"/> <input type="checkbox"/> <input type="checkbox"/> <input type="checkbox"/> <input type="checkbox"/>	<input type="checkbox"/> <input type="checkbox"/> <input type="checkbox"/> <input type="checkbox"/> <input type="checkbox"/>	
59. IP 65	1. Rear clamp	1. Ø 10 mm	1. A $\tilde{A}$ +B $\tilde{B}$ +0 $\tilde{0}$	1. Radial cable	0. 11...30 VDC / NPN Open collector 11..30 VDC	(*)	GT00. -40°C	
59A. IP 67	2. Frontal clamp	2. Ø 12 mm 3. Ø 14 mm	2. A $\tilde{A}$ +B $\tilde{B}$	2. Radial 90.9512 M23 12p CW 3. Radial 90.9508 M12 8p CCW	1. 11..30 VDC / Line driver differential Push-Pull 11..30 VDC 2. 5 VDC / RS422 5 VDC (compatible TTL) 6. 11...30 VDC / RS422 5 VDC (compatible TTL)			

Order your reference  
Step file 3D

[info@encoderhohner.com](mailto:info@encoderhohner.com)  
service available in 24 h

(\*) 10.000 to 50.000 pulses with interpolation. Available 10.000 direct optical pulses without interpolating upon request.

The required anti-rotation system is not included in the reference (order separately). Anti-rotation system is supplied disassembled and includes the screws required for assembly to the encoder. All systems available in the sections "MOUNTING ACCESSORIES".

### MECHANICAL SPECIFICATIONS

Materials	Housing: Aluminium Flange: Aluminium Shaft: Stainless Steel
Bearings	Ballraces
Bearings lifetime	1x10 <sup>10</sup> rev.
Housing fixing	Anti-rotation pin, Flexible flange or Anti-turn stick
Permitted misalignment	±0.5 mm axial, ±0.3 mm radial (90.1014, 90.1024)
Shaft fixing	Front or Rear clamp
Hollow shaft diameter	10, 12 or 14 mm
Maximum number of revolutions permitted mechanically	6000 rpm
Protection against dust and splashes according to DIN EN 60529	IP65 - Standard IP67 - Option 59A
Rotor inertia moment	30 gcm <sup>2</sup> (59) 40 gcm <sup>2</sup> (59A)
Starting torque at 20°C (68°F)	≤ 0,02 Nm (59) ≤ 0,04 Nm (59A)
Maximum load permitted on axial shaft	40 N
Maximum load permitted on radial shaft	80 N
Weight aprox.	0,5 Kg
Operating temperature range	-20°C to +80°C - Standard -40°C to +80°C - Special Customer GT00
Vibration according to DIN EN 60068-2-6	100 m/s <sup>2</sup> (10Hz...2000Hz)
Shock according to DIN EN 60068-2-27	1000 m/s <sup>2</sup> (6ms)
Maximum pulses per turn	50.000
Radial connection	2 meters cable or industrial connector M12 or M23 (other cable lengths available on order) <b>Female connector included</b>

# SERIE 59

## HIGH RESOLUTION HOLLOW SHAFT INCREMENTAL ENCODER FOR INDUSTRIAL APPLICATIONS

### OUTPUT SIGNALS

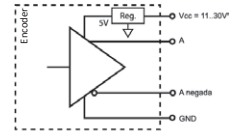
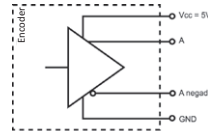
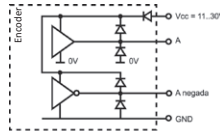
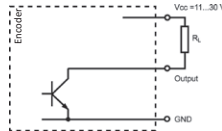

OUTPUT CIRCUIT	NPN Open Collector	Push-Pull Differential	RS422 (TTL compatible)	RS422 (TTL compatible)
Reference code	0	1	2	6
Power supply	11...30 VDC	11...30 VDC	5 VDC ±5%	11...30 VDC
Output voltage	11...30 VDC	11...30 VDC	5 VDC	5 VDC
Consumption	40 mA	Typical: 45 mA Max: 150 mA	Typical: 70 mA Max: 150 mA	Typical: 80 mA Max: 160 mA
Max. load capability / channel	40 mA	±30 mA	±20 mA	±20 mA
Length of cable allowed	50 m (24 VDC)	100 m	1200 m	1200 m
"Low" signal level	VOL < 0.4 VDC (24 VDC)	VOL < 2.5 VDC	VOL < 0.5 VDC	VOL < 0.5 VDC
"High" signal level	VOH > 22 VDC (24 VDC)	VOH > VCC - 3 VDC	VOH > 2.5 VDC	VOH > 2.5 VDC
Frequency	100 kHz	200 kHz	300 kHz	300 kHz
Short circuit protection	Not permanent	Yes	Yes	Yes
Protection polarity inversion	Yes	Yes	No	Yes

Channel B leads (90° electric) channel A, view from the shaft, shaft rotating clockwise

### CONNECTION



	95.0008003 Cable 3x2x0,14+2x0,34	90.9508 M12 8p CCW	90.9512 M23 12p CW
GND	Black	1	1
VCC	Red	2	2
A	Yellow	3	3
B	Green	4	4
~A	Brown	5	5
~B	Blue	6	6
0 (reference)	Grey	7	7
~0	Orange	8	8
Shield*	Shield	Housing	Housing

(\*) Shield connected to the encoder housing. It is recommended to connect the end of the wire shield to the ground of the equipment where the encoder is connected. ⚡

# SERIE 59

## HIGH RESOLUTION HOLLOW SHAFT INCREMENTAL ENCODER FOR INDUSTRIAL APPLICATIONS

### ACCESSORIES EXAMPLES

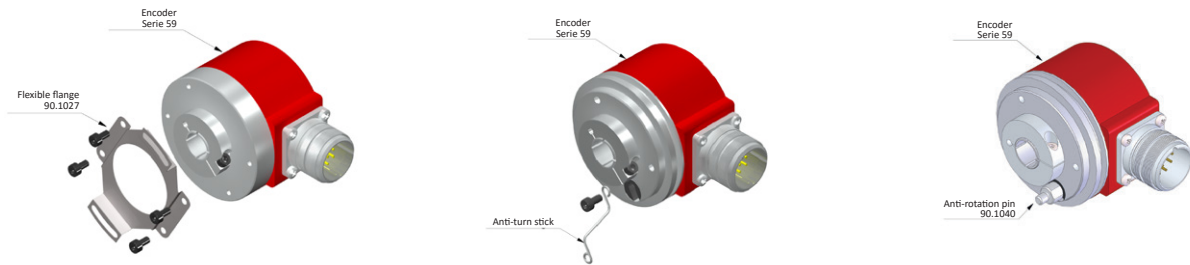

All the accessories available in the section "MOUNTING ACCESSORIES".

### CONNECTION DIMENSIONS

Female connector included

#### Connection 2 Radial 90.9512

Fixation 1  
Rear clamp

**90.9512**  
M23 12p  
male panel  
clockwise

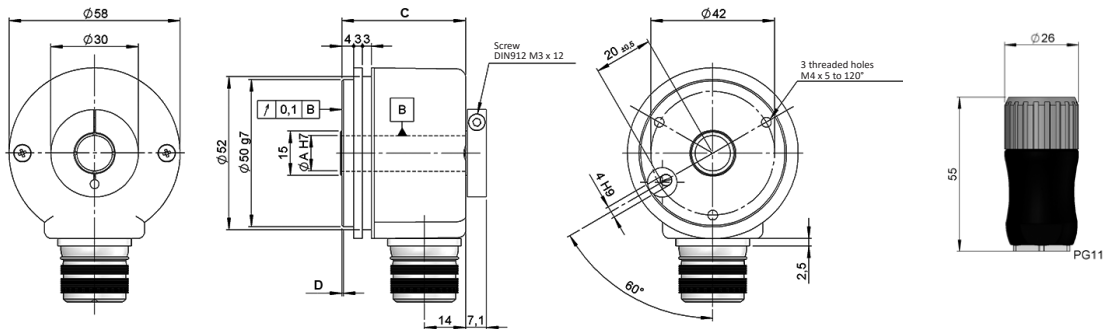

#### Connection 3 Radial 90.9508

Fixation 2  
Frontal clamp

**90.9508**  
M12 8p  
male panel  
counter clockwise

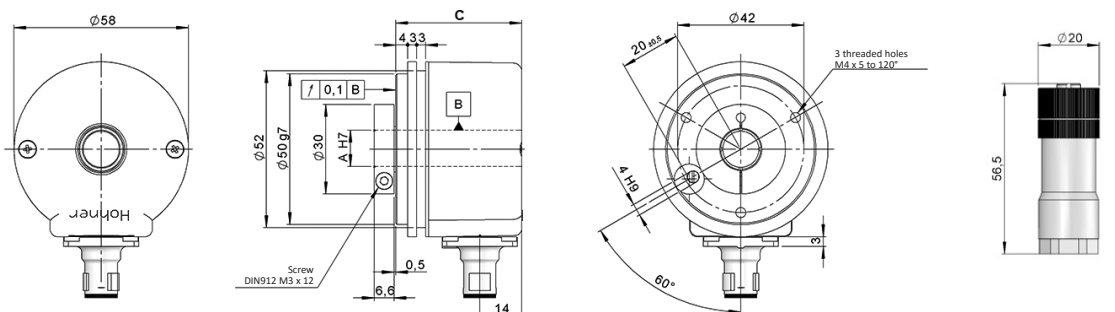

# SERIE 59

## HIGH RESOLUTION HOLLOW SHAFT INCREMENTAL ENCODER FOR INDUSTRIAL APPLICATIONS

### ANTI-ROTATION SYSTEMS DIMENSIONS

Anti-rotation pin  
90.1040

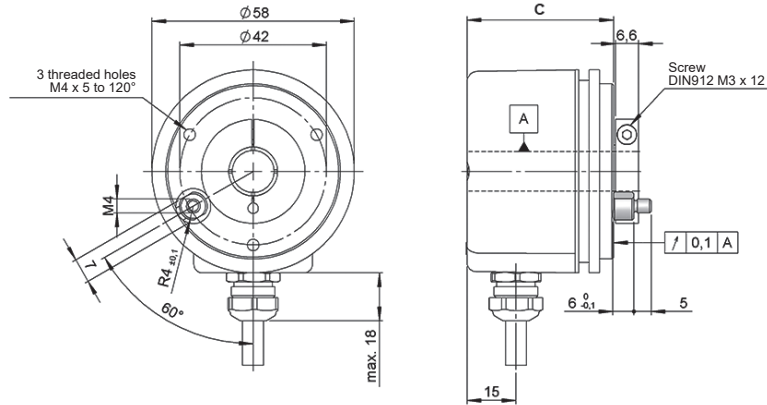

90.1040



Flexible flange  
90.1014

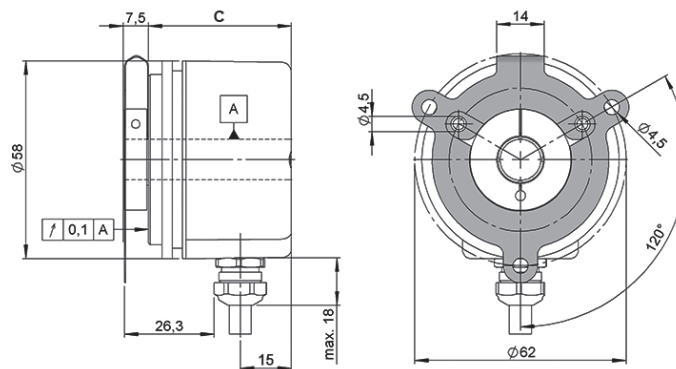

90.1014



Flexible flange  
90.1018

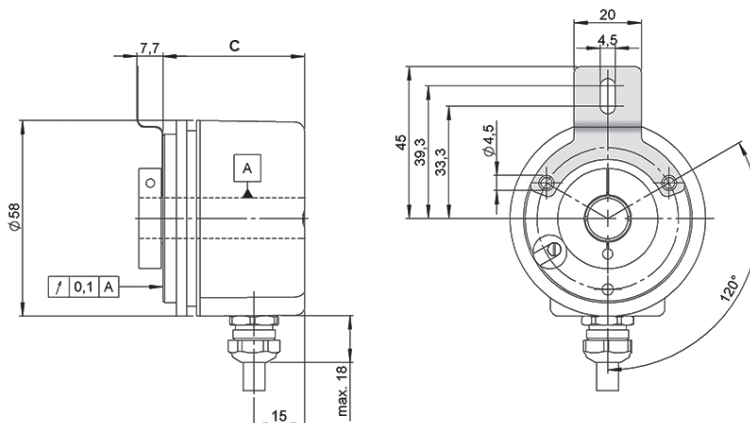

90.1018



# SERIE 59

## HIGH RESOLUTION HOLLOW SHAFT INCREMENTAL ENCODER FOR INDUSTRIAL APPLICATIONS

Flexible flange  
90.1024

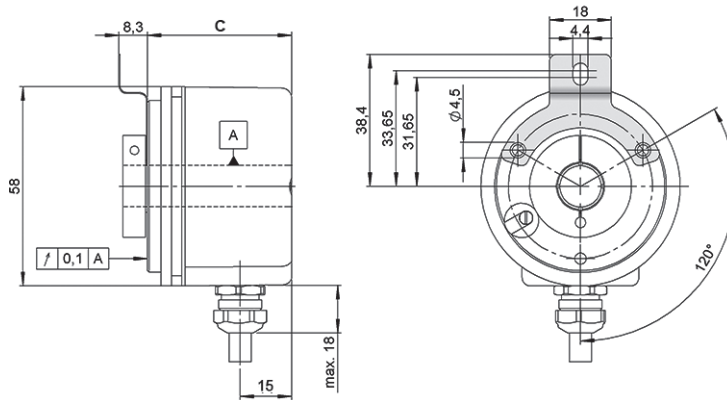

90.1024



Flexible flange  
90.1027

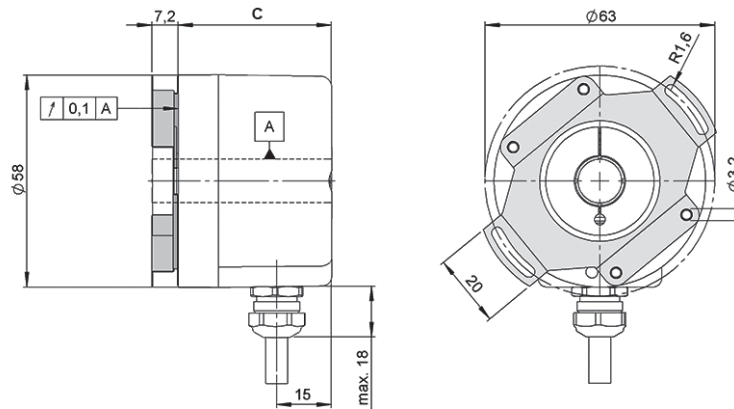

90.1027



The flexible flange requires special customer GG02

Flexible flange  
90.1075

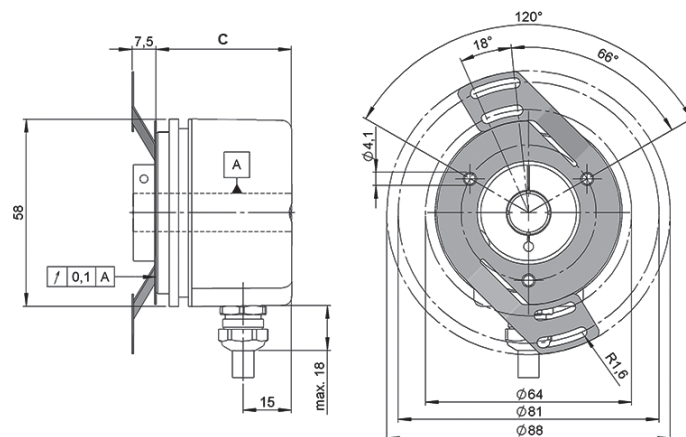

90.1075



# SERIE 59

## HIGH RESOLUTION HOLLOW SHAFT INCREMENTAL ENCODER FOR INDUSTRIAL APPLICATIONS

Flexible flange  
90.1095

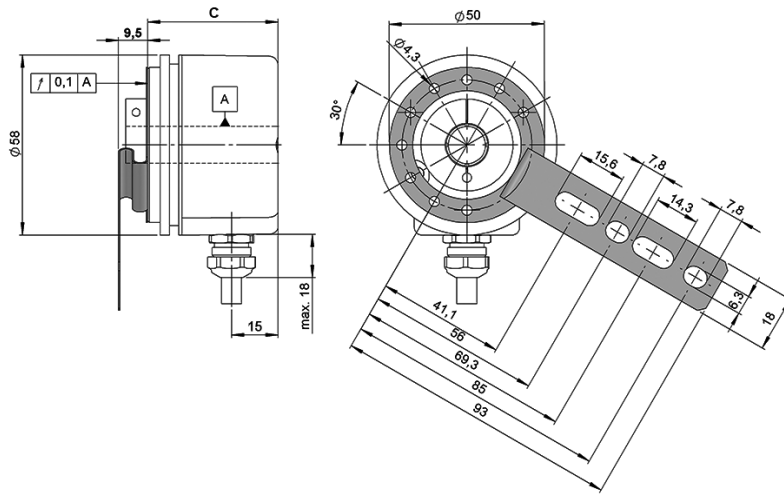

90.1095

Anti-turn stick

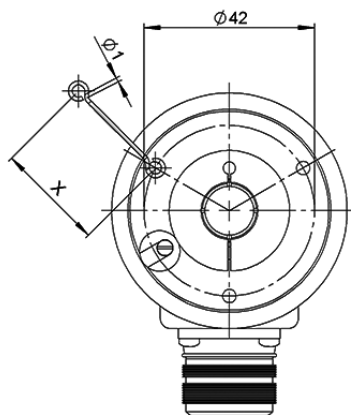

90.1033	X= 33 mm
90.1044	X= 83 mm
90.1043	X= 132 mm

(\*) other lenght available on order