



HIRSCHMANN

A **BELDEN** BRAND

User Manual

Installation

Industrial ETHERNET Workgroup Switch MACH104-PoEP Family Full Gigabit



MACH104-16TX-PoEP+2X
MACH104-16TX-PoEP+2X-R
MACH104-16TX-PoEP+2X-E

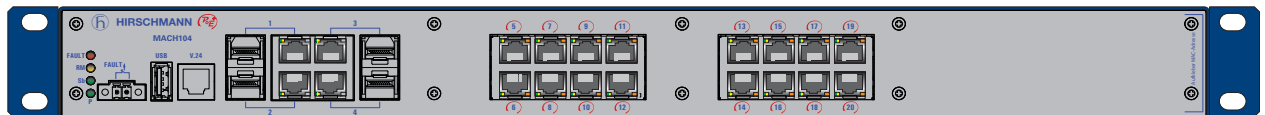

MACH104-16TX-PoEP
MACH104-16TX-PoEP-R
MACH104-16TX-PoEP-E



039782001040312000

MACH104-PoEP
Release 04 03/2012

Technical Support
<https://hirschmann-support.belden.eu.com>

The naming of copyrighted trademarks in this manual, even when not specially indicated, should not be taken to mean that these names may be considered as free in the sense of the trademark and tradename protection law and hence that they may be freely used by anyone.

© 2012 Hirschmann Automation and Control GmbH

Manuals and software are protected by copyright. All rights reserved. The copying, reproduction, translation, conversion into any electronic medium or machine scannable form is not permitted, either in whole or in part. An exception is the preparation of a backup copy of the software for your own use. For devices with embedded software, the end-user license agreement on the enclosed CD applies.

The performance features described here are binding only if they have been expressly agreed when the contract was made. This document was produced by Hirschmann Automation and Control GmbH according to the best of the company's knowledge. Hirschmann reserves the right to change the contents of this document without prior notice. Hirschmann can give no guarantee in respect of the correctness or accuracy of the information in this document.

Hirschmann can accept no responsibility for damages, resulting from the use of the network components or the associated operating software. In addition, we refer to the conditions of use specified in the license contract.

You can get the latest version of this manual on the Internet at the Hirschmann product site (www.hirschmann.com).

Printed in Germany
Hirschmann Automation and Control GmbH
Stuttgarter Str. 45-51
72654 Neckartenzlingen
Germany
Tel.: +49 1805 141538

Contents

Safety instructions	4
About this manual	11
Legend	11
1 Device description	12
1.1 General device description	12
1.2 Description of the device variants	13
1.3 Device views	15
1.3.1 Front view	15
1.3.2 Rear view	16
1.4 PoE ports	17
1.5 Combo ports	18
1.6 SFP/XFP modules	19
2 Assembly and start-up	20
2.1 Installing the device	20
2.1.1 Unpacking and checking	20
2.1.2 Installing the SFP/XFP modules (optional)	21
2.1.3 “FAULT” signal contact	21
2.1.4 Dimension drawings	23
2.1.5 Installing the device and grounding	24
2.1.6 Supply voltage	27
2.1.7 Startup procedure	28
2.1.8 Connecting the data lines	28
2.2 Display elements	30
2.3 Basic set-up	32
2.4 Maintenance	34
2.5 Disassembly	35
3 Technical data	36
A Further Support	45

Safety instructions

■ Important Information

Notice: Read these instructions carefully, and look at the equipment to become familiar with the device before trying to install, operate, or maintain it. The following special messages may appear throughout this documentation or on the equipment to warn of potential hazards or to call attention to information that clarifies or simplifies a procedure.



The addition of this symbol to a Danger or Warning safety label indicates that an electrical hazard exists, which will result in personal injury if the instructions are not followed.



This is the safety alert symbol. It is used to alert you to potential personal injury hazards. Obey all safety messages that follow this symbol to avoid possible injury or death.



DANGER

DANGER indicates an imminently hazardous situation which, if not avoided, **will result in** death or serious injury.



WARNING

WARNING indicates a potentially hazardous situation which, if not avoided, **can result in** death or serious injury.



CAUTION

CAUTION indicates a potentially hazardous situation which, if not avoided, **can result in** minor or moderate injury.

Note: Contains important information on the product, on how to manage the product, or on the respective section of the documentation to which your special attention is being drawn.

■ **Certified usage**

The device may only be employed for the purposes described in the catalog and technical description, and only in conjunction with external devices and components recommended or approved by the manufacturer. The product can only be operated correctly and safely if it is transported, stored, installed and assembled properly and correctly. Furthermore, it must be operated and serviced carefully.

■ **Supply voltage**



WARNING

ELECTRIC SHOCK

Only connect a supply voltage that corresponds to the type plate of your device.

Failure to follow these instructions can result in death, serious injury, or equipment damage.



WARNING

FIRE HAZARD

This applies to the following device variants only:

- ▶ MACH104-16TX-PoEP-E
- ▶ MACH104-16TX-PoEP+2X-E

Install an input fuse with a maximum rating of 10 A, characteristic B, into the supply line to the voltage input.

Use conductors with a minimum cross-section of 1 mm² for the supply line to the voltage input.

Non-adherence to these instructions can lead to death, serious physical injury or material damage.

The supply voltage is electrically isolated from the housing.

This applies to the following device variants only:

- ▶ MACH104-16TX-PoEP-E
- ▶ MACH104-16TX-PoEP+2X-E

Exclusively connect SELV circuits with the voltage restrictions in accordance with IEC/EN 60950-1 to the supply voltage connections. Ensure that the connected supply voltage complies with the requirements according to IEEE 802.3af or IEEE 802.3at.

- Use undamaged parts.
- The device does not contain any service components. Internal fuses are only triggered if there is a fault in the device. If the device is not functioning correctly, or if it is damaged, switch off the voltage supply and return the device to the plant for inspection.
- Only switch on the device when the housing is closed.
- Only use connection cables that are permitted for the specified temperature range.
- Relevant for North America:
Only use copper wire/conductors of class 1, 60/75°C or 75°C.
- Make sure that the disconnecting device is easily accessible so that the MACH104-PoEP device can be disconnected from the mains voltage.
If you disconnect the device from the mains voltage using
 - the plug in the socket
 - an on/off switchit must be easily accessible.

Note: This applies to the following device variants only:

- ▶ MACH104-16TX-PoEP-R
- ▶ MACH104-16TX-PoEP+2X-R

Pull **both** non-heating plugs to disconnect the device from mains voltage.

■ Shielding ground

The shielding ground of the connectable twisted pair lines is connected to the protective conductor connection via the front panel.

- Beware of possible short circuits when connecting a cable section with conductive shielding braiding.

■ Housing



DANGER

HAZARD OF ELECTRIC SHOCK

Never insert sharp objects (small screwdrivers, wires, etc.) into the inside of the product.

Failure to follow these instructions will result in death, serious injury, or equipment damage.



CAUTION

OVERHEATING OF THE DEVICE

When installing the device, ensure that the ventilation slots are not covered.

Non-adherence to these instructions can lead to minor physical injury or material damage.

Only technicians authorized by the manufacturer are permitted to open the housing.

The device is grounded via the voltage supply socket.

- Make sure that the electrical installation meets local or nationally applicable safety regulations.
- The ventilation slots must not be covered to promote free air circulation.
- The clearance to the ventilation slots of the housing must be at least 10 cm (3.94 in).
- The device must be installed in the horizontal or upright position, either as a table unit in the switch cabinet (see fig. 4) or on the wall (see fig. 5).
- If you are operating the device in a 19" switch cabinet: install sliding/mounting rails for holding the device (see fig. 3).
- In order to fix the device to a concrete wall choose screws with a thread major diameter of at least 5 mm.

■ Environment

The device may only be operated at the specified surrounding air temperature (temperature of the surrounding air at a distance of up to 5 cm (1.97 in) from the device) and relative air humidity specified in the technical data.

- Install the device in a location where the climatic threshold values specified in the technical data will be observed.
- Use the device only in an environment within the pollution degree specified in the technical data.

■ Qualification requirements for personnel

Qualified personnel as understood in this manual and the warning signs, are persons who are familiar with the setup, assembly, startup, and operation of this product and are appropriately qualified for their job. This includes, for example, those persons who have been:

- ▶ trained or directed or authorized to switch on and off, to ground and to label power circuits and devices or systems in accordance with current safety engineering standards;
- ▶ trained or directed in the care and use of appropriate safety equipment in accordance with the current standards of safety engineering;
- ▶ trained in providing first aid.

■ General safety instructions

Electricity is used to operate this equipment. Comply with every detail of the safety requirements specified in the operating instructions regarding the voltages to apply.

see "Supply voltage" on page 5.

Non-observance of these safety instructions can therefore cause material damage and/or injuries.

- Only appropriately qualified personnel should work on this device or in its vicinity. These personnel must be thoroughly familiar with the warnings and maintenance procedures in accordance with this operating manual.
- The proper and safe operation of this device depends on proper handling during transport, proper storage and assembly, and conscientious operation and maintenance procedures.
- Never start operation with damaged components.
- Only use the devices in accordance with this manual. In particular, observe the warnings and safety-related information.
- Any work that may be required on the electrical installation may only be carried out by personnel trained for this purpose.
- Please note that products recommended as accessories may have characteristics that do not fully correspond to those of the corresponding product. This may limit their possible usage in the overall system.
- POE connections are for use only to POE networks without routing to the outside plant and are considered as SELV circuits.

Note: LED or LASER components in compliance with IEC 60825-1 (2007):

CLASS 1 LASER PRODUCT
CLASS 1 LED PRODUCT

■ **National and international safety regulations**

- Make sure that the electrical installation meets local or nationally applicable safety regulations.

■ **CE marking**

The devices comply with the regulations contained in the following European directive(s):

Device variant	Directive
MACH104-16TX-PoEP	2004/108/EC
MACH104-16TX-PoEP+2X	Directive of the European Parliament and the council for standardizing the regulations of member states with regard to electromagnetic compatibility.
MACH104-16TX-PoEP-R	
MACH104-16TX-PoEP+2X-R	
MACH104-16TX-PoEP-E	
MACH104-16TX-PoEP+2X-E	
MACH104-16TX-PoEP	2006/95/EC
MACH104-16TX-PoEP+2X	Directive of the European Parliament and the council for standardizing the regulations of member states with regard to electrical equipment to be used within specific voltage ranges.
MACH104-16TX-PoEP-R	
MACH104-16TX-PoEP+2X-R	
MACH104-16TX-PoEP+2X-E	

In accordance with the above-named EU directive(s), the EU conformity declaration will be at the disposal of the relevant authorities at the following address:

Hirschmann Automation and Control GmbH
Stuttgarter Str. 45-51
72654 Neckartenzlingen
Tel.: +49 1805 141538

The product can be used in the industrial sector.

- ▶ Interference immunity: EN 61000-6-2:2005
- ▶ Emitted interference: EN 55022:2010
- ▶ Safety: EN 60950-1:2006 + A11:2009 + A1:2010

Warning! This is a class A device. This device can cause interference in living areas, and in this case the operator may be required to take appropriate measures.

Note: The assembly guidelines provided in these instructions must be strictly adhered to in order to observe the EMC threshold values.

■ **FCC note:**

This device complies with part 15 of FCC rules. Operation is subject to the following two conditions : (1) This device may not cause harmful interference; (2) this device must accept any interference received, including interference that may cause undesired operation.

Appropriate testing has established that this device fulfills the requirements of a class A digital device in line with part 15 of the FCC regulations.

These requirements are designed to provide sufficient protection against interference when the device is being used in a business environment. The device creates and uses high frequencies and can radiate same, and if it is not installed and used in accordance with this operating manual, it can cause radio transmission interference. The use of this device in a living area can also cause interference, and in this case the user is obliged to cover the costs of removing the interference.

■ **Recycling note**

After usage, this product must be disposed of properly as electronic waste, in accordance with the current disposal regulations of your county, state and country.

About this manual

The “Installation” user manual contains a device description, safety instructions, a description of the display, and the other information that you need to install the device.

The following manuals are available as PDF files on the CD-ROM supplied:

- ▶ Installation user manual
- ▶ Basic Configuration user manual
- ▶ Redundancy Configuration user manual
- ▶ Graphical User Interface reference manual
- ▶ Command Line Interface user manual

The Industrial HiVision Network Management Software provides you with additional options for smooth configuration and monitoring:

- ▶ Simultaneous configuration of multiple devices
- ▶ Graphic interface with network layout
- ▶ Auto-topology discovery
- ▶ Event log
- ▶ Event handling
- ▶ Client/server structure
- ▶ Browser interface
- ▶ ActiveX control for SCADA integration
- ▶ SNMP/OPC gateway.

Legend

The symbols used in this manual have the following meanings:

▶	Listing
□	Work step
■	Subheading

1 Device description

1.1 General device description

The devices of the MACH104-PoEP family provide you with a range of variants ([see on page 13 “Description of the device variants”](#)).

The MACH104-PoEP devices are designed for the special requirements of industrial automation. They meet the relevant industry standards, provide very high operational reliability, even under extreme conditions, and also long-term reliability and flexibility.

The devices allow you to set up switched industrial Ethernet networks that conform to the IEEE 802.3 standard using copper wires or optical fibers in a line or ring structure.

The following installation options are available:

- ▶ 19" switch cabinet
- ▶ Mounting on the wall
- ▶ Mounting on a flat surface

You can choose various media to connect terminal devices and other infrastructure components:

- ▶ twisted pair cable
- ▶ multimode F/O
- ▶ singlemode F/O

The ring redundancy concept allows the network to be reconfigured quickly after a failure.

There are convenient options for managing the device. Administer your devices via:

- ▶ a Web browser
- ▶ Telnet
- ▶ management software (e.g. Industrial HiVision)
- ▶ a V.24 interface (locally on the Switch)

The devices provide you with a large range of functions, which the manuals for the operating software inform you about. These manuals are available as PDF files on the CD ROM provided, or you can download them from the Internet on the Hirschmann product pages (www.hirschmann.com).

The Hirschmann network components help you ensure continuous communication across all levels of the company.

1.2 Description of the device variants

The [table 1](#) informs you about the identification characteristics of your device.

Designation	Order number
MACH104-16TX-PoEP	942 030-001
MACH104-16TX-PoEP-R	942 026-001
MACH104-16TX-PoEP-E	942 027-001
MACH104-16TX-PoEP+2X	942 031-001
MACH104-16TX-PoEP+2X-R	942 033-001
MACH104-16TX-PoEP+2X-E	942 032-001

Table 1: Device types: Designation, order number

The product designation of your device is made from combining the product characteristics in accordance with the following table. The corresponding short designation is in column 3.

Item	Characteristic	Characteristic value	Description
1 to 17	Basic properties of all device variants	MACH104-16TX-PoEP	Industrial Ethernet Workgroup Switch with:
			4 × 1000-Mbit/s Combo Ports (see page 18 "Combo ports")
			16 × 1000-Mbit/s Twisted-Pair Ports with PoE+ (see page 17 "PoE ports")
18 + x	Special properties of the device variants	Blank	Rated voltage range AC 100 V to 240 V, 50 to 60 Hz
		-R	▶ Rated voltage range AC 100 V to 240 V, 50 to 60 Hz ▶ Redundant power supply
		-E	For the use of type-1-powered devices (PoE): ▶ Nominal voltage DC 48 V
			For the use of type-2-powered devices (PoE+): ▶ Nominal voltage DC 54 V
		+2X	▶ Additionally: 2 × 10-Gbit/s F/O ports (see page 30 "10 Gbit/s F/O connection") ▶ Rated voltage range AC 100 V to 240 V, 50 to 60 Hz
		+2X-R	▶ Additionally: 2 × 10-Gbit/s F/O ports (see page 30 "10 Gbit/s F/O connection") ▶ Rated voltage range AC 100 V to 240 V, 50 to 60 Hz ▶ Redundant power supply
		+2X-E	Additionally: 2 × 10-Gbit/s F/O ports (see page 30 "10 Gbit/s F/O connection") For the use of type-1-powered devices (PoE): ▶ Nominal voltage DC 48 V
		For the use of type-2-powered devices (PoE+): ▶ Nominal voltage DC 54 V	

Table 2: Product designation and product properties

1.3 Device views

1.3.1 Front view

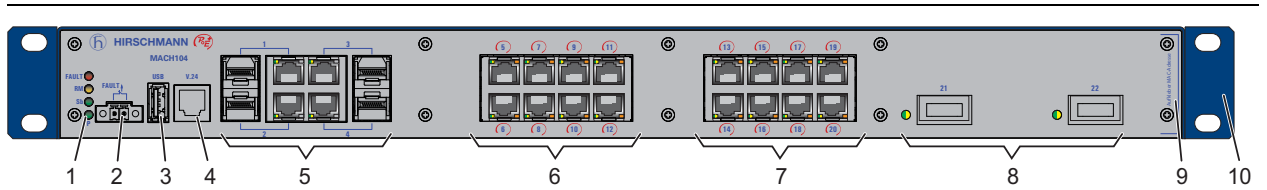

1	LED display elements	Device Status (see page 30 “Device state”)
2	Signal contact	(see page 21 ““FAULT” signal contact”)
3	USB interface	(see page 33 “USB interface”)
4	V.24 interface	(see page 33 “V.24 interface (external management)”)
5	Ports 1 to 4	1000-Mbit/s Combo Ports (see page 18 “Combo ports”)
6	Ports 5 to 12	1000-Mbit/s Twisted-Pair Ports with PoE+ (see page 17 “PoE ports”)
7	Ports 13 to 20	1000-Mbit/s Twisted-Pair Ports with PoE+ (see page 17 “PoE ports”)
8	Ports 21, 22	10-Gbit/s F/O ports (see page 30 “10 Gbit/s F/O connection”)
9	MAC address of device (label)	
10	Bracket	(see page 25 “Mounting the MACH104-PoEP in a switch cabinet”) (see page 26 “Installing the MACH104-PoEP on the wall”)

*Table 3: Front view of device variants:
MACH104-16TX-PoEP+2X
MACH104-16TX-PoEP+2X-R
MACH104-16TX-PoEP+2X-E*

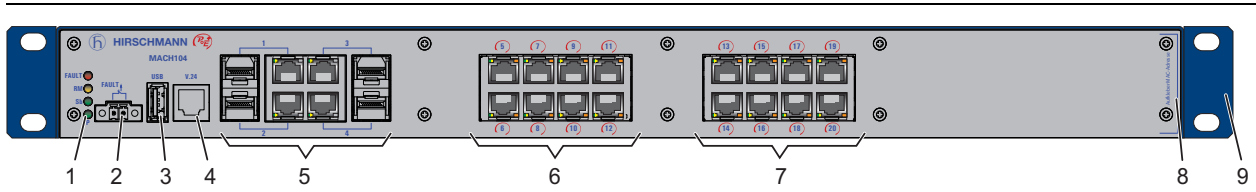

1	LED display elements	Device Status (see page 30 "Device state")
2	Signal contact	(see page 21 "FAULT" signal contact)
3	USB interface	(see page 33 "USB interface")
4	V.24 interface	(see page 33 "V.24 interface (external management)")
5	Ports 1 to 4	1000-Mbit/s Combo Ports (see page 18 "Combo ports")
6	Ports 5 to 12	1000-Mbit/s Twisted-Pair Ports with PoE+ (see page 17 "PoE ports")
7	Ports 13 to 20	1000-Mbit/s Twisted-Pair Ports with PoE+ (see page 17 "PoE ports")
8	MAC address of device (label)	
9	Bracket	(see page 25 "Mounting the MACH104-PoEP in a switch cabinet") (see page 26 "Installing the MACH104-PoEP on the wall")

Table 4: Front view of device variants:
 MACH104-16TX-PoEP
 MACH104-16TX-PoEP-R
 MACH104-16TX-PoEP-E

1.3.2 Rear view



1	Non-heating appliance socket	Connecting the supply voltage (see page 27 "MACH104-16TX-PoEP MACH104-16TX-PoEP+2X")
---	------------------------------	---

Table 5: Rear view of device variants:
 MACH104-16TX-PoEP
 MACH104-16TX-PoEP+2X



1	Non-heating appliance socket	Connecting the supply voltage ▶ Supply voltage 2 (see page 27 “MACH104-16TX-PoEP-R MACH104-16TX-PoEP+2X-R”)
2	Non-heating appliance socket	Connecting the supply voltage ▶ Supply voltage 1 (see page 27 “MACH104-16TX-PoEP-R MACH104-16TX-PoEP+2X-R”)

Table 6: Rear view of device variants:
MACH104-16TX-PoEP-R
MACH104-16TX-PoEP+2X-R

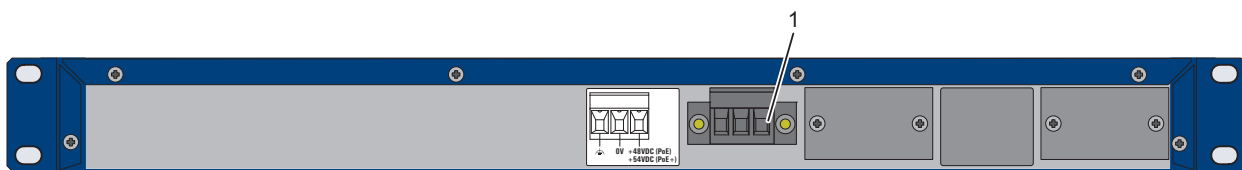

1	3-pin DC socket	Connecting the supply voltage (see page 28 “MACH104-16TX-PoEP-E MACH104-16TX-PoEP+2X-E”)
---	-----------------	---

Table 7: Rear view of device variants:
MACH104-16TX-PoEP-E
MACH104-16TX-PoEP+2X-E

1.4 PoE ports

Note: POE connections are for use only to POE networks without routing to the outside plant and are considered as SELV circuits.

Note: For more information see [page 28 “10/100/1000 Mbit/s twisted pair connection”](#).

Some twisted-pair ports support Power over Ethernet (PoE):

Ports	PoE support
1 to 4	No
5 to 20	Yes

Table 8: Twisted-pair ports and PoE support

The PoE ports allow the connection and remote supply of, for example, IP telephones (Voice over IP), webcams, sensors, printer servers and WLAN access points. With PoE, these terminal devices are powered by the twisted-pair cable.

The PoE support of the ports complies with the following standards:

Standard	Description	
IEEE 802.3af	Brief description	PoE
	Classes	max. Powered Device (PD) class 0 (15,4 W)
IEEE 802.3at	Brief description	PoE+
	Classes	max. Powered Device (PD) class 4 (30 W)

Table 9: PoE support: Standards

The following applies to PoE ports:

- ▶ The PoE voltage is input via the wire pairs transmitting the signal (phantom voltage).
- ▶ The individual ports (joint PoE voltage) are not electrically insulated from each other.
- ▶ Maximum power available to PoE terminal devices:
240 W

Note: We recommend to distribute the PoE power equally between the two port groups (ports 5 to 12 and ports 13 to 20).

1.5 Combo ports

Alternatively, F/O (via SFP modules) or twisted pairs can be connected to the combo ports.

Media type	Connection options		
Twisted pair	Standard	ISO/IEC 8802-03 10BASE-T/100BASE-TX/ 1000BASE-T	
		Connection type	RJ45
	(see page 28 “10/100/1000 Mbit/s twisted pair connection”)		
Fiber optic cable	either	Standard	ISO/IEC 8802-03 100BASE-FX
		Connection type	Fast Ethernet SFP module
	(see page 29 “100 Mbit/s F/O connection”)		
	or	Standard	ISO/IEC 8802-03 1000BASE-SX/LX
		Connection type	1-Gigabit Ethernet SFP module
(see page 29 “1 Gbit/s F/O connection”)			

Table 10: Combo ports: Connection options

When you use an SFP module, you get an optical interface. You thus deactivate the corresponding TP interface.

1.6 SFP/XFP modules

SFP/XFP modules are optical transceivers.

SFP is the acronym for Small Form-factor Pluggable which is also commonly known as mini-GBIC (GigaBit Interface Converter).

Fast Ethernet SFP modules as well as 1-Gigabit Ethernet SFP modules are available for your device.

XFP modules are slightly larger than SFP modules. They support 10-Gigabit Ethernet only.

Note: Only use Hirschmann SFP/XFP modules ([see on page 42 “Accessories”](#)).

2 Assembly and start-up

The devices have been developed for practical application in a harsh industrial environment.

On delivery, the device is ready for operation.

The following procedure has been proven to be successful for the assembly of the device:

- ▶ Unpacking and checking
- ▶ Installing SFP/XFP modules (optional)
- ▶ Signal contact
- ▶ Installing the device and grounding
- ▶ Supply voltage
- ▶ Startup
- ▶ Connecting the data lines

2.1 Installing the device

Note: Observe the following information: [page 4 “Safety instructions”](#).

2.1.1 Unpacking and checking

- Check that the contents of the package are complete ([see page 42 “Scope of delivery”](#)).
- Check the individual parts for transport damage.

2.1.2 Installing the SFP/XFP modules (optional)



Figure 1: SFP and XFP modules

1 - Fast ETHERNET fiberoptic SFP module

2 - Gigabit ETHERNET fiberoptic SFP module

3 - 10 Gigabit ETHERNET fiberoptic XFP module

- Before attaching an SFP or XFP module, first remove the protective cap of the SFP/XFP module.
- Push the SFP/XFP module with the lock closed into the socket until it latches audibly in place.



Note: Only use Hirschmann SFP/XFP modules ([see on page 42 “Accessories”](#)).

2.1.3 “FAULT” signal contact

Note: The location at the device is described on [page 15 “Front view”](#).

The signal contacts are connected via a 2-pin terminal block with screw locking.

- ▶ The signal contact (“FAULT”, for pin assignment of terminal block, see [fig. 2](#)) monitors the functioning of the device, thus enabling remote diagnostics. You can specify the type of function monitoring in the Management.
- ▶ You can also use the Management to switch the signal contact manually and thus control external devices.

A break in contact is used to report the following conditions via the potential-free signal contact (relay contact, closed circuit):

- ▶ The detected inoperability of at least one of the two voltage supplies (voltage supply 1 or 2 is below the threshold value).
- ▶ A continuous malfunction in the device (internal supply voltage).

- ▶ The loss of connection at at least one port. The report of the link status can be masked by the Management for each port. In the delivery state, link status monitoring is deactivated.
- ▶ The removal of the AutoConfiguration Adapter.
- ▶ The temperature threshold has been exceeded or has not been reached.

The following condition is also reported in RM mode:

- ▶ Ring redundancy reserve is available. On delivery, there is no ring redundancy monitoring.

■ **Connecting the terminal block**

- Pull the terminal block off the device and connect the signal lines.

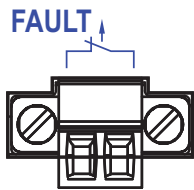

Figure 2: 2-pin terminal block

Note: Please note the electrical ratings for the signal contact ([see on page 36 “General technical data”](#)).

Note: Relevant for North America:

The tightening torque for fixing the signal contact terminal block to the device is 3 lb in (0.34 Nm).

- Mount the terminal block for the signal contact on the front of the device using the screw locking. Check whether the terminal block is mounted correctly and screwed on.

2.1.4 Dimension drawings

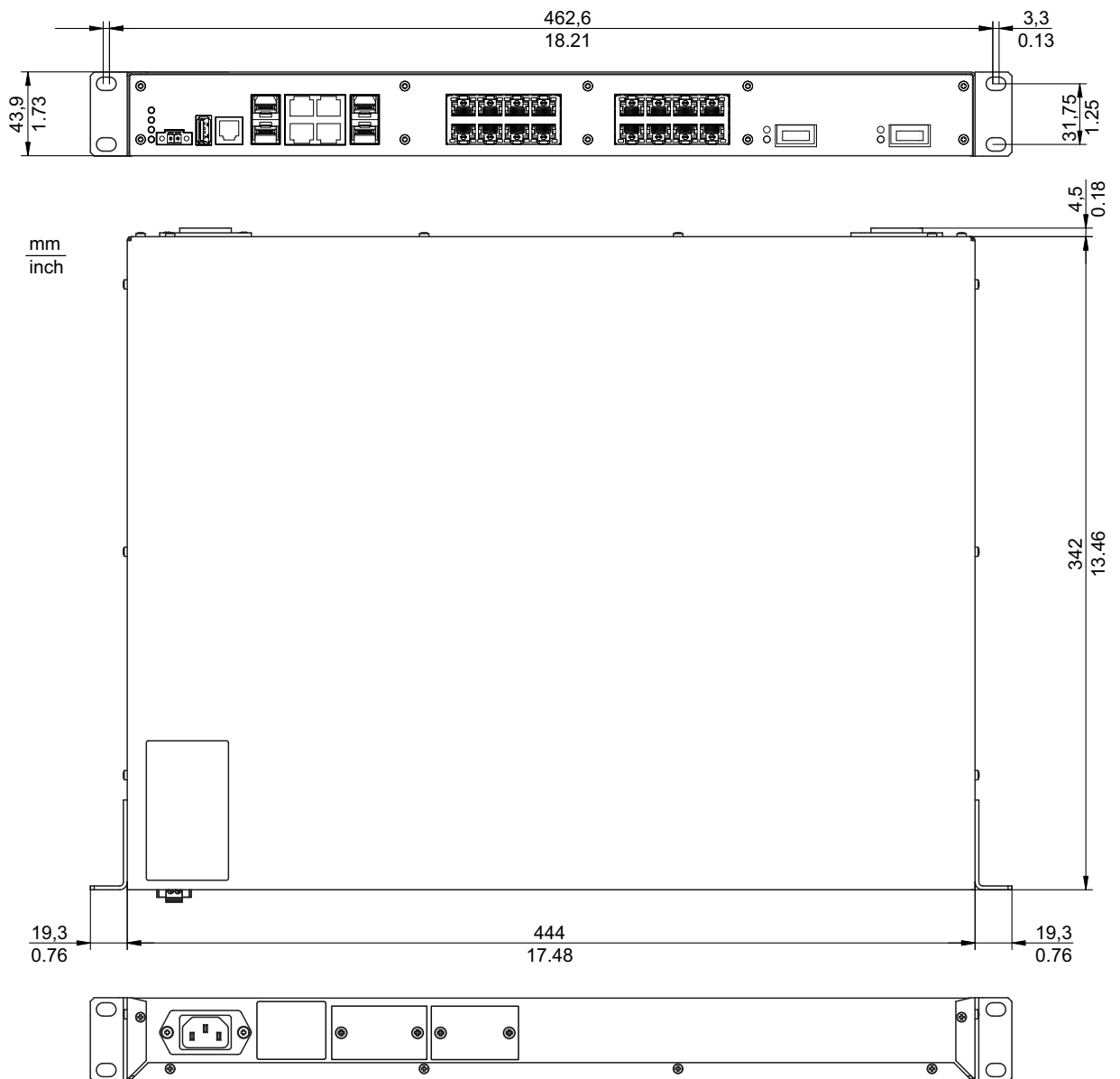

2.1.5 Installing the device and grounding



CAUTION

OVERHEATING OF THE DEVICE

When installing the device, ensure that the ventilation slots are not covered.

Non-adherence to these instructions can lead to minor physical injury or material damage.

The device can be mounted on a flat surface, in a 19" standard switch cabinet, or on the wall.

■ Selecting the assembly location

Consider the following criteria when selecting the location for mounting your device:

- The installation location should be close to a power outlet.
- The climatic threshold values listed in the technical data must be adhered to.
- The ventilation slots must not be covered to promote free air circulation.
- The clearance to the ventilation slots of the housing must be at least 10 cm (3.94 in).
- The installation location should be freely accessible for the installation and for maintenance and repairs.
- The LED display elements should be clearly and easily visible.
- Make sure that the TP cable is far enough away from power cables and other sources of possible electrical interference.
- Make sure that the device is connected to a separate power source with a ground connection and a main voltage in line with the technical data, and that the device is supplied with power via a separate isolator or power switch. It is recommended to use overvoltage protection for all devices.

Note: The shielding ground of the connectable industrial twisted pair lines is connected to the front panel as a conductor.

■ Mounting the MACH104-PoEP as a table unit

- Install the device observing the criteria outlined in section [“Selecting the assembly location”](#) on page 24.

■ Mounting the MACH104-PoEP in a switch cabinet

Note: Install the device in the 19" switch cabinet using sliding or mounting rails.

This provides a more stable position of your device in environments subject to vibration.

For more information on sliding/mounting rails and how to install them, please contact your switch cabinet manufacturer.

The devices are designed to be mounted in a 19" rack.

- Make sure there is sufficient ventilation. If necessary, provide a fan for the 19" rack. This will prevent the basic devices from overheating.
- Measure the depth of the 19" rack so as to allow the main cable, and any power supply cables, to be fitted from the back, and the data cables to be fitted from the front.
- Install the sliding/mounting rails in the 19" switch cabinet as instructed by the manufacturer, and make sure the device is resting on both rails.

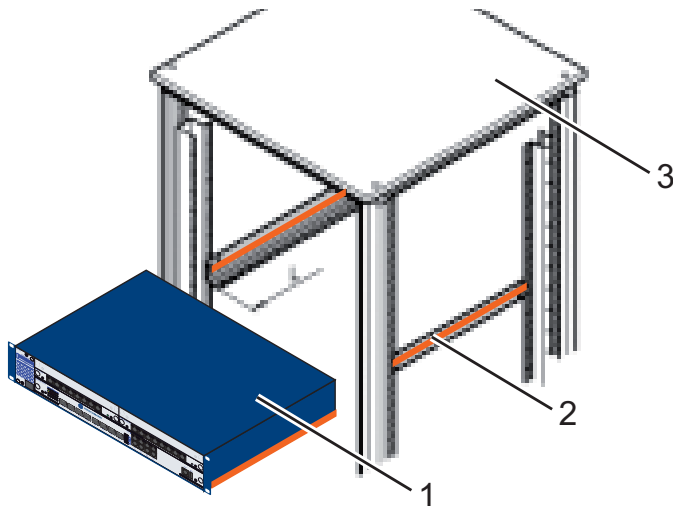

Figure 3: Installation in the switch cabinet with sliding/mounting rails
1 - MACH104-PoEP device
2 - Sliding/mounting rail
3 - 19" cabinet

On delivery, two brackets are attached to the sides of the device (see figure below).

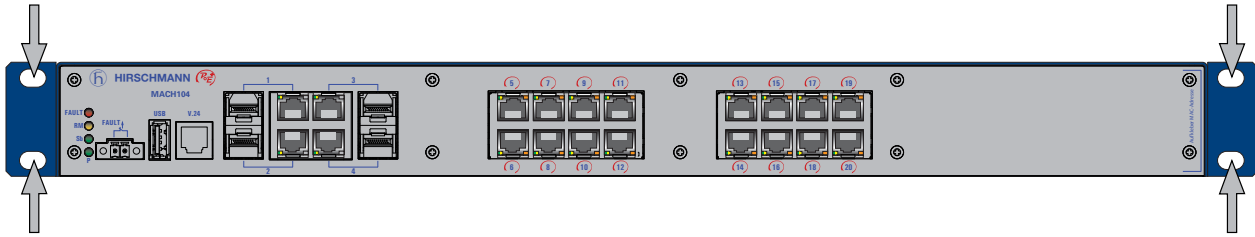

Figure 4: Mounting the MACH104-PoEP in the 19" cabinet

- Fasten the device by screwing the brackets to the switch cabinet.

Note: When operating the device in environments with strong vibrations, the device can be fastened with two additional brackets at the back of the switch cabinet (see on page 42 “Accessories”), not included in the delivery.

■ Installing the MACH104-PoEP on the wall

Note: In order to fix the device to a concrete wall choose screws with a thread major diameter of at least 5 mm.

- Use the pre-mounted brackets included in the delivery as shown in the following figure (see fig. 5).
- Attach two additional brackets to the device (see on page 42 “Accessories”, not included in the delivery) as shown in the following figure (see fig. 5).
- Fasten the device by screwing the brackets to the wall.

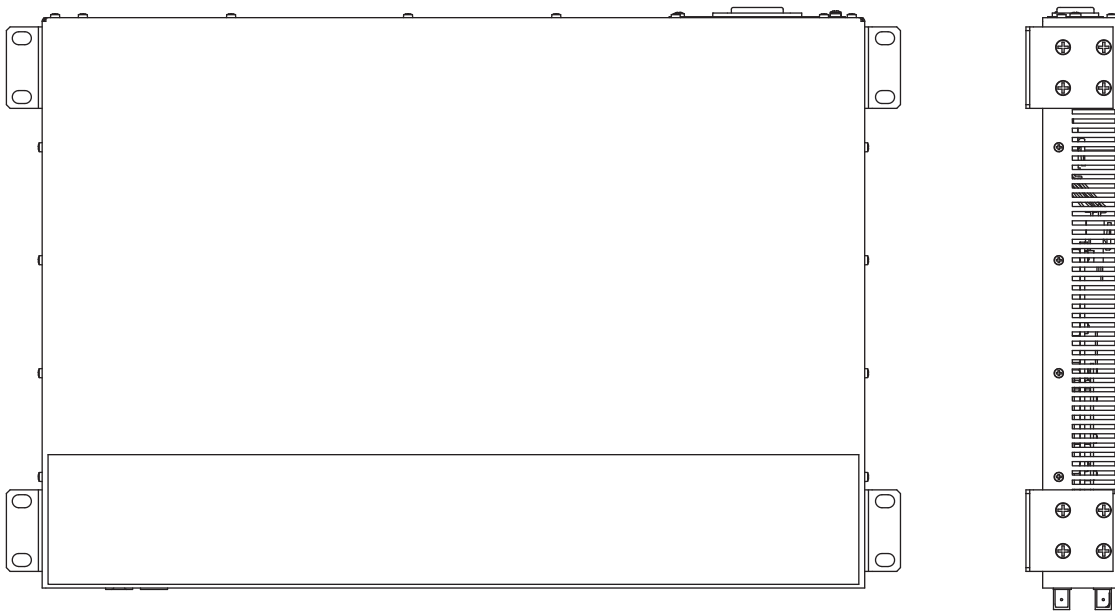

Figure 5: Vertical mounting on the wall

Note: The shielding ground of the connectable industrial twisted pair lines is connected to the front panel as a conductor.

■ **Grounding**

The device is grounded via the power supply connections.

2.1.6 Supply voltage

WARNING

ELECTRIC SHOCK

Only connect a supply voltage that corresponds to the type plate of your device.

Failure to follow these instructions can result in death, serious injury, or equipment damage.

Note: Observe the following information: [page 5 “Supply voltage”](#).

Note: Observe the information about the voltages to be connected: [page 36 “Technical data”](#)

■ **MACH104-16TX-PoEP MACH104-16TX-PoEP+2X**

For the supply voltage, the following applies:

- ▶ A power module providing the PoE voltage and the internal supply voltage is integrated in the device.
- ▶ Supply voltage is connected via a non-heating appliance socket.

Note: The location at the device is described on [table 16 “Rear view of device variants: MACH104-16TX-PoEP MACH104-16TX-PoEP+2X”](#).

- ▶ The input voltage is electrically isolated from the housing.

■ **MACH104-16TX-PoEP-R MACH104-16TX-PoEP+2X-R**

For the supply voltage, the following applies:

- ▶ The supply voltage can be connected redundantly.
- ▶ Two power modules providing the PoE voltage and the internal supply voltage are integrated in the device. The power modules operate in load-sharing mode.
- ▶ Supply voltage is connected via non-heating appliance sockets.

Note: The location at the device is described on [table 17 “Rear view of device variants: MACH104-16TX-PoEP-R MACH104-16TX-PoEP+2X-R”](#).

- ▶ The input voltage is electrically isolated from the housing.
- ▶ Both inputs are uncoupled from supply voltage.

Note: With non-redundant supply of the main voltage, the device reports a loss of power. You can avert this message by applying the supply voltage via both inputs, or by changing the configuration in the Management.

■ **MACH104-16TX-PoEP-E** **MACH104-16TX-PoEP+2X-E**

For the supply voltage, the following applies:

- ▶ PoE voltage and internal supply voltage are provided by an external power module.
- ▶ The voltage supply is connected via a 3-pin terminal block with snap locks.

Note: The location at the device is described on [table 17 “Rear view of device variants: MACH104-16TX-PoEP-E MACH104-16TX-PoEP+2X-E”](#).

Figure	Pin	Function
	1	Protective grounding
	2	Minus terminal of the supply voltage
	3	Plus terminal of the supply voltage

Table 11: Pin assignment of the 3-pin terminal block for the supply voltage

2.1.7 Startup procedure

By connecting the voltage supply via the voltage supply socket(s), you start the operation of the device.

2.1.8 Connecting the data lines

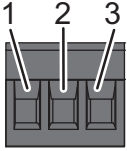
■ **10/100/1000 Mbit/s twisted pair connection**

These connections are RJ45 sockets.

10/100/1000 Mbit/s TP ports enable the connection of terminal devices or independent network segments according to the IEEE 802.3 10BASE-T/100BASE-TX/1000BASE-T standard.

These ports support:

- ▶ Autonegotiation
- ▶ Autopolarity
- ▶ Autocrossing (if autonegotiation is activated)
- ▶ 1000 Mbit/s full duplex
- ▶ 100 Mbit/s half-duplex mode, 100 Mbit/s full duplex mode
- ▶ 10 Mbit/s half-duplex mode, 10 Mbit/s full duplex mode

Note: Some of these ports also support Power over Ethernet (PoE). For more information see [page 17 “PoE ports”](#).

State on delivery: autonegotiation activated.

The socket housing is electrically connected to the front panel.

The pin assignment corresponds to MDI-X.

Figure	Pin	Function	Ports with PoE support: PoE voltage feed
	1	BI_DB+	Minus terminal of the supply voltage
	2	BI_DB-	Minus terminal of the supply voltage
	3	BI_DA+	Plus terminal of the supply voltage
	4	BI_DD+	
	5	BI_DD-	
	6	BI_DA-	Plus terminal of the supply voltage
	7	BI_DC+	
	8	BI_DC-	

Table 12: Pin assignment of a 1000 MBit/s TP interface in MDI-X mode, RJ45 socket - for PoE with the power supplied via the wire pairs transmitting the signal

■ 100 Mbit/s F/O connection

These ports are SFP slots.

100 MBit/s F/O ports enable the connection of terminal devices or independent network segments in compliance with the IEEE 802.3 100BASE-FX standard.

These ports support:

- ▶ Full or half duplex mode

State on delivery: full duplex FDX

Note: Make sure that the LH ports are only connected with LH ports, SM ports are only connected with SM ports, and MM ports only with MM ports.

■ 1 Gbit/s F/O connection

These ports are SFP slots.

1 Gbit/s F/O ports enable the connection of terminal devices or independent network segments according to the IEEE 802.3 1000BASE-SX/1000BASE-LX standard.

These ports support:

- ▶ Autonegotiation
- ▶ Full duplex mode

State on delivery: autonegotiation activated.

Note: Make sure that the LH ports are only connected with LH ports, SX ports are only connected with SX ports, and LX ports only with LX ports.

■ 10 Gbit/s F/O connection

10 Gbit/s F/O ports (XFP slot) enable the connection of terminal devices or independent network segments in compliance with the IEEE 802.3ae-2002 (ISO/IEC 8802-3:2002) 10GBASE-SR/LR standard. These ports support:

- ▶ Full duplex mode

State on delivery: full duplex FDX

Note: Make sure that the SR ports are only connected with SR ports, LR ports are only connected with LR ports, ER ports only with ER ports, and ZR ports only with ZR ports.

2.2 Display elements

After the operating voltage is set up, the software starts and initializes itself. Afterwards, the device performs a self-test. During this process, various LEDs light up.

The process takes around 15 seconds.

■ Device state

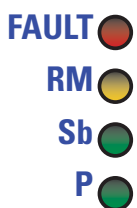

These LEDs provide information about conditions which affect the operation of the whole device.

Note: The location at the device is described on [page 15 “Front view”](#).

The following table applies to the stated device variants only:

- ▶ MACH104-16TX-PoEP-R
- ▶ MACH104-16TX-PoEP+2X-R

LED	Display	Color	Activity	Meaning
P	Power supply	Green	Lights up	The supply voltages 1 and 2 are on.
		Yellow	Lights up	The supply voltages 1 or 2 are on.
			None	The supply voltages 1 and 2 are too low.

The following table applies to the stated device variants only:

- ▶ MACH104-16TX-PoEP
- ▶ MACH104-16TX-PoEP-E
- ▶ MACH104-16TX-PoEP+2X
- ▶ MACH104-16TX-PoEP+2X-E

LED	Display	Color	Activity	Meaning
P	Power supply	Green	Lights up	The supply voltage is on.
			None	The supply voltage is too low.

The following table applies to all device variants:

LED	Display	Color	Activity	Meaning
Sb	Stand-by		None	Stand-by mode not enabled
		Green	Lights up	Standby mode enabled
FAULT	Signal contact		None	Signal contact is closed, it is not reporting a detected error.
		Red	Lights up	The signal contact is open, it is reporting an error.
RM	Ring Manager		None	The RM function is deactivated.
		Green	Lights up	The RM function is active. The redundant port is disabled.
			flashing	Incorrect configuration of the HIPER-Ring (e.g. the ring is not connected to the ring port).
		Yellow	Lights up	The RM function is active. The redundant port is enabled.
RM and Sb	ACA memory operation		Flashing alternately	Error in the memory operation
			flash synchronously – 2 x per period	Save a configuration file from the ACA to the device.
			flash synchronously – 1 x per period	Saving a configuration file from the device to the ACA.

If the manual adjustment is active on the “FAULT” signal contact, then the detected error display is independent of the setting of the signal contact.

■ Port state

These LEDs display port-related information.
The LEDs are directly located at the ports.
The following table applies to ports 5 to 20:

LED	Display	Color	Activity	Meaning
left LED	Link status		None	No valid connection
		Green	Lights up	Valid connection
			Flashes 1 time a period	Port is switched to stand by
			Flashes 3 times a period	Port is disabled
Yellow	Flashing	Data traffic		
right LED	PoE		None	No PoE voltage at port.
		orange	Lights up	No PoE voltage at port.
			Flashes 1 time a period	No PoE voltage at port because power capacity is exhausted.
			Flashes 3 times a period	The PoE voltage is deactivated in the management system.

The following table applies to all other ports:

LED	Display	Color	Activity	Meaning
left LED	Link status		None	No valid connection
		Green	Lights up	Valid connection
			Flashes 1 time a period	Port is switched to stand by
			Flashes 3 times a period	Port is disabled
Yellow	Flashing	Data traffic		
right LED (if present)			permanently active	

2.3 Basic set-up

The IP parameters must be entered when the device is installed for the first time. The device provides 6 options for configuring IP addresses:

- ▶ Entry via V.24 connection
- ▶ Entry using the HiDiscovery protocol via the application HiDiscovery or Industrial HiVision
- ▶ Configuration via BOOTP
- ▶ Configuration via DHCP
- ▶ Configuration via DHCP Option 82
- ▶ Auto Configuration Adapter

Further information on the basic settings of the device can be found in the “Basic Configuration” user manual on the CD ROM.

■ Default settings

- ▶ IP address: The device looks for the IP address using DHCP
- ▶ Management password:
user, password: public (read only)
admin, password: private (read and write)
- ▶ V.24 data rate: 9,600 Baud
- ▶ Ring redundancy: off
- ▶ Ethernet ports: link status is not evaluated (signal contact)
- ▶ Optical 100 Mbit/s ports: 100 Mbit/s full duplex
All other ports: autonegotiation
- ▶ Redundancy manager switched off
(DIP switch RM and Stand-by: ON)
- ▶ Stand-by coupling switched off
(DIP switch RM and Stand-by: ON)
Port 3 = control port, port 4 = coupling port for redundant ring coupling
- ▶ Rapid Spanning Tree: on

■ USB interface

The USB socket has an interface for the local connection of an AutoConfiguration Adapter (part number ACA 21-USB see on [page 42](#) “Accessories”). It is used for saving/loading the configuration and for loading the software.

Figure	Pin	Operation
	1	VCC (VBus)
	2	- Data
	3	+ Data
	4	Ground (GND)

Table 13: Pin assignment of the USB interface

■ V.24 interface (external management)

The V.24 interface is an RJ11 socket.

The V.24 interface is a serial interface which allows you to connect the following devices locally:

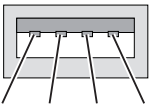
- ▶ An external management station (VT100 terminal or PC with appropriate terminal emulation). This enables you to set up a connection to the Command Line Interface (CLI) and to the system monitor.
- ▶ An AutoConfiguration Adapter ACA 11

VT 100 terminal settings	
Speed	9,600 Baud
Data	8 bit
Stopbit	1 bit
Handshake	off
Parity	none

The socket housing is electrically connected to the front panel of the device.

The V.24 interface is not electrically isolated from the supply voltage.

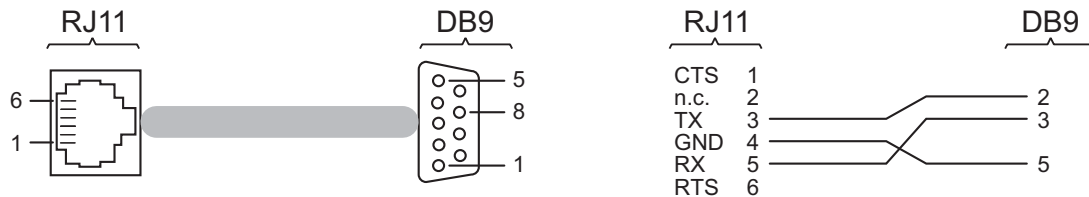

Figure 6: Pin assignment of the V.24 interface and the DB9 connector

Note: You will find the order number for the terminal cable, which is ordered separately, in the Technical Data chapter (see on page 36 “Technical data”).

You will find a description of the V.24 interface in the “Basic Configuration User Manual” on the CD-ROM.

2.4 Maintenance

- When designing this device, Hirschmann was largely able to forego using wear parts. The parts subject to wear are dimensioned to last longer than the lifetime of the product when it is operated normally. Operate this device according to the specifications (see “Technical data”).
- Relays are subject to natural wear. This wear depends on the frequency of the switching operations. Depending on the frequency of the switching operations, check the volume resistance of the closed relay contacts and the switching function.
- Hirschmann are continually working on improving and developing their software. You should regularly check whether there is a new version of the software that provides you with additional benefits. You will find software information and downloads on the product pages of the Hirschmann website.
- Depending on the degree of pollution in the operating environment, check at regular intervals that the ventilation slots in the device are not obstructed.

2.5 Disassembly

■ Disassembling the device

- To detach the device from the switch cabinet or the wall, remove the screws from the brackets on the device.

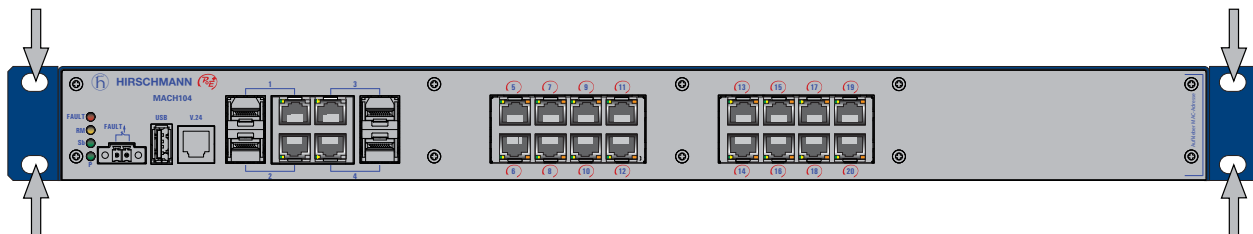

Figure 7: Disassembling the device

■ Disassembling the SFP modules

- Pull the SFP module out of the socket by means of the opened lock.



Figure 8: Deinstalling an SFP module

3 Technical data

■ General technical data

Dimensions W × H × D	MACH104-...	448 mm x 44 mm x 345 mm (without brackets)
Weight	MACH104-16TX-PoEP	4.6 kg
	MACH104-16TX-PoEP+2X	
	MACH104-16TX-PoEP-R	5.2 kg
	MACH104-16TX-PoEP+2X-R	
	MACH104-16TX-PoEP-E	4.4 kg
	MACH104-16TX-PoEP+2X-E	
Operating voltage	MACH104-16TX-PoEP	Rated voltage range AC
	MACH104-16TX-PoEP+2X	100 V to 240 V, 50 to 60 Hz
	MACH104-16TX-PoEP-R	Max. voltage range AC
	MACH104-16TX-PoEP+2X-R	90 V to 264 V, 47 to 63 Hz
	MACH104-16TX-PoEP-E	Note: Exclusively connect SELV circuits with the voltage restrictions in accordance with IEC/EN 60950-1 to the supply voltage connections. Ensure that the connected supply voltage complies with the requirements according to IEEE 802.3af or IEEE 802.3at.
MACH104-16TX-PoEP+2X-E		
		For the use of type-1-powered devices (PoE): Nominal voltage DC 48 V Max. voltage range DC 45 V to 57 V
		For the use of type-2-powered devices (PoE+): Nominal voltage DC 54 V Max. voltage range DC 51 V to 57 V
Current consumption	MACH104-16TX-PoEP	max. 1.5 A (240 V AC)
	MACH104-16TX-PoEP+2X	max. 3.5 A (100 V AC)
	MACH104-16TX-PoEP-R	
	MACH104-16TX-PoEP+2X-R	
	MACH104-16TX-PoEP-E	max. 4.8 A (54 V DC)
	MACH104-16TX-PoEP+2X-E	max. 5.5 A (48 V DC)
Activation current	MACH104-16TX-PoEP	typ. <40 A at 240 V AC and cold start
	MACH104-16TX-PoEP+2X	
	MACH104-16TX-PoEP-R	
	MACH104-16TX-PoEP+2X-R	
	MACH104-16TX-PoEP-E	typ. <6 A
	MACH104-16TX-PoEP+2X-E	
PoE power	Maximum number of Powered Devices (PDs)	8 × Powered Device (PD) class 4 (30 W)
		16 × Powered Device (PD) class 0 (15.4 W)

Power failure bypass	MACH104-16TX-PoEP	> 20 ms
	MACH104-16TX-PoEP+2X	
	MACH104-16TX-PoEP-R	
	MACH104-16TX-PoEP+2X-R	
	MACH104-16TX-PoEP-E	> 10 ms
	MACH104-16TX-PoEP+2X-E	
Note: Applies to the basic device only, not to the Powered Devices connected.		
Overload current protection at input	Non-replaceable fuse	
Climatic conditions during operation	Surrounding air temperature	0 °C to +50 °C (see page 40 “Power consumption/power output, temperature range and order numbers”)
	Humidity	10% ... 95% (non-condensing)
	Air pressure	minimum 795 hPa (+2000 m) maximum 1060 hPa (-400 m)
Climatic conditions during storage	Surrounding air temperature	-20 °C to +85 °C
	Humidity	10% ... 95% (non-condensing)
	Air pressure	minimum 700 hPa (+3000 m) maximum 1060 hPa (-400 m)
“FAULT” signal contact	Switching current	max. 1 A, SELV
	Switching voltage	max. 60 V DC or max. 30 V AC, SELV
Pollution degree	2	
Protection classes	Laser protection	Class 1 according to EN 60825-1 (2007)
	Degree of protection	IP 30

■ EMC and immunity

EMC interference immunity		
IEC/EN 61000-4-2	Electrostatic discharge	
	Contact discharge	4 kV
	Air discharge	8 kV
IEC/EN 61000-4-3	Electromagnetic field	
	80 MHz ... 3000 MHz	10 V/m
IEC/EN 61000-4-4	Fast transients (burst)	
	Power line	2 kV
	Data line	4 kV
IEC/EN 61000-4-5	Voltage surges	
	This applies to the following device variants only:	
	▶ MACH104-16TX-PoEP-E	
	▶ MACH104-16TX-PoEP+2X-E	
	Power line, line / line	0.5 kV
	Power line, line / earth	1 kV
	Data line	1 kV
	This applies to the following device variants only:	
	▶ MACH104-16TX-PoEP	
	▶ MACH104-16TX-PoEP+2X	
▶ MACH104-16TX-PoEP-R		
▶ MACH104-16TX-PoEP+2X-R		
Power line, line / line	1 kV	
Power line, line / earth	2 kV	
Data line	1 kV	
IEC/EN 61000-4-6	Line-conducted interference voltages	
	150 kHz ... 80 MHz	10 V
EMC emitted interference		
EN 55022	Class A	Yes
FCC 47 CFR Part 15	Class A	Yes

■ Network range

Note: The line lengths specified for the transceivers apply for the respective fiber data (fiber attenuation and BLP/dispersion).

TP port	
Length of a twisted pair segment	max. 100 m / 328 ft (cat5e cable with 1000BASE-T)

Table 14: TP port 10BASE-T / 100BASE-TX / 1000BASE-T

Product code M-FAST-SFP-...	Wave length	Fiber	System attenuation	Example for F/O line length ^a	Fiber attenuation	BLP/ dispersion
-MM/LC...	MM 1310 nm	50/125 μm	0-8 dB	0-5 km	1.0 dB/km	800 MHz*km
-MM/LC...	MM 1310 nm	62.5/125 μm	0-11 dB	0-4 km	1.0 dB/km	500 MHz*km
-SM/LC...	SM 1310 nm	9/125 μm	0-13 dB	0-25 km	0.4 dB/km	3.5 ps/(nm*km)
-SM+/LC...	SM 1310 nm	9/125 μm	10-29 dB	25-65 km	0.4 dB/km	3.5 ps/(nm*km)
-LH/LC...	SM 1550 nm	9/125 μm	10-29 dB	47-104 km	0.25 dB/km	19 ps/(nm*km)
-LH/LC...	SM 1550 nm	9/125 μm	10-29 dB	55-140 km	0.18 dB/km ^b	18 ps/(nm*km)

Table 15: Fiber port 100BASE-FX (SFP fiber optic Fast Ethernet Transceiver)

- a. including 3 dB system reserve when compliance with the fiber data is observed
b. with ultra-low-loss optical fiber

Product code M-SFP-...	Wave length	Fiber	System attenuation	Example for F/O line length ^a	Fiber attenuation	BLP ^b / dispersion
-SX/LC...	MM 850 nm	50/125 μm	0-7.5 dB	0-550 m	3.0 dB/km	400 MHz*km
-SX/LC...	MM 850 nm	62.5/125 μm	0-7.5 dB	0-275 m	3.2 dB/km	200 MHz*km
-MX/LC	MM 1310 nm	50/125 μm	0-8 dB	2 km ^c	1.0 dB/km	500 MHz*km
-MX/LC	MM 1310 nm	62.5/125 μm	0-8 dB	1 km	1.0 dB/km	500 MHz*km
-LX/LC...	MM 1310 nm ^d	50/125 μm	0-10.5 dB	0-550 m	1.0 dB/km	800 MHz*km
-LX/LC...	MM 1310 nm ^d	62.5/125 μm	0-10.5 dB	0-550 m	1.0 dB/km	500 MHz*km
-LX/LC...	SM 1310 nm	9/125 μm	0-10.5 dB	0-20 km ^e	0.4 dB/km	3.5 ps/(nm*km)
-LX+/LC...	SM 1310 nm	9/125 μm	5-20 dB	14-42 km	0.4 dB/km	3.5 ps/(nm*km)
-LH/LC...	LH 1550 nm	9/125 μm	5-22 dB	23-80 km	0.25 dB/km	19 ps/(nm*km)
-LH+/LC	LH 1550 nm	9/125 μm	15-30 dB	71-108 km	0.25 dB/km	19 ps/(nm*km)
-LH+/LC	LH 1550 nm	9/125 μm	15-30 dB	71-128 km	0.21 dB/km (typically)	19 ps/(nm*km)

Table 16: Fiber port 1000BASE-FX (SFP fiber optic Gigabit Ethernet Transceiver)

- a. including 3 dB system reserve when compliance with the fiber data is observed
b. The bandwidth length product cannot be used to calculate the expansion.
c. Distances of up to 3 km reachable, 1000 MHz*km (1300 nm)
d. With F/O adapter compliant with IEEE 802.3-2002 clause 38 (single-mode fiber offset-launch mode conditioning patch cord)
e. including 2.5 dB system reserve when compliance with the fiber data is observed

Product code M-XFP-...	Wave length	Fiber	System attenuation	Example for fiber optic cable length	Fiber attenuation	BLP ^a / dispersion
-SR/LC	MM 850 nm	50/125 μm	0-8.1 dB	max. 66 m	3.0 dB/km	400 MHz*km
-SR/LC	MM 850 nm	50/125 μm	0-8.1 dB	max. 82 m	3.0 dB/km	500 MHz*km
-SR/LC	MM 850 nm	50/125 μm	0-8.1 dB	max. 300 m	3.0 dB/km	2,000 MHz*km
-SR/LC	MM 850 nm	62.5/125 μm	0-8.1 dB	max. 26 m	3.2 dB/km	160 MHz*km
-SR/LC	MM 850 nm	62.5/125 μm	0-8.1 dB	max. 33 m	3.2 dB/km	200 MHz*km
-LR/LC	SM 1310 nm	9/125 μm	0-7.8 dB	typ. 10 km	0.4 dB/km	3.5 ps/(nm*km)
-ER/LC	SM 1550 nm	9/125 μm	3-15 dB	10-40 km	0.25 dB/km	19 ps/(nm*km)
-ZR/LC	SM 1550 nm	9/125 μm	11-24 dB	40-80 km	0.25 dB/km	;19 ps/(nm*km)

Table 17: F/O port 10GBASE-SR/LR (XFP FO 10-Gigabit ETHERNET transceiver)

a. The bandwidth length product cannot be used to calculate the expansion.

Product code M-SFP-BIDI...	Wave length TX	Wave length RX	Fiber	System attenuation	Example for F/O line length ^a	Fiber attenuation	Dispersion
Type A LX/LC EEC	SM 1310 nm	1550 nm	9/125 μm	0-11 dB	0-20 km	0.4 dB/km	3.5 ps/(nm*km)
Type B LX/LC EEC	SM 1550 nm	1310 nm	9/125 μm	0-11 dB	0-20 km	0.25 dB/km	19 ps/(nm*km)
Type A LH/LC EEC	LH 1490 nm	1590 nm	9/125 μm	5-24 dB	23-80 km	0.25 dB/km	19 ps/(nm*km)
Type B LH/LC EEC	LH 1590 nm	1490 nm	9/125 μm	5-24 dB	23-80 km	0.25 dB/km	19 ps/(nm*km)

Table 18: F/O port (bidirectional Gigabit Ethernet SFP Transceiver)

a. including 3 dB system reserve when compliance with the fiber data is observed

MM = Multimode, SM = Singlemode, LH = Singlemode Longhaul

■ Power consumption/power output, temperature range and order numbers

MACH104-PoEP device	Maximum power consumption	Maximum power output
MACH104-16TX-PoEP MACH104-16TX-PoEP+2X	max. 330 W	max. 300 BTU/h
MACH104-16TX-PoEP-R MACH104-16TX-PoEP+2X-R	max. 340 W	max. 340 BTU/h
MACH104-16TX-PoEP-E MACH104-16TX-PoEP+2X-E	max. 300 W	max. 200 BTU/h

MACH104-PoEPdevice	Operating temperature	Order number
MACH104-16TX-PoEP	0 °C to +50 °C	942 030-001
MACH104-16TX-PoEP-R	0 °C to +50 °C	942 026-001
MACH104-16TX-PoEP-E	0 °C to +50 °C	942 027-001
MACH104-16TX-PoEP+2X	0 °C to +50 °C	942 031-001
MACH104-16TX-PoEP+2X-R	0 °C to +50 °C	942 033-001
MACH104-16TX-PoEP+2X-E	0 °C to +50 °C	942 032-001

Note: This applies to the following device variants only:

- ▶ MACH104-16TX-PoEP+2X
- ▶ MACH104-16TX-PoEP+2X-R
- ▶ MACH104-16TX-PoEP+2X-E

If XFP modules without extension "EEC" are used, a maximum operating temperature of 40 °C must not be exceeded. For operating temperatures between 40 °C and 50 °C, modules of the type M-XFP...EEC must be used.

■ Scope of delivery

Device	Scope of delivery
MACH104-16TX-PoEP MACH104-16TX-PoEP+2X	Device <hr/> Terminal block ▶ 1 × ▶ 2-pin ▶ for signal contact <hr/> 2 × Brackets with fastening screws (pre-mounted) <hr/> Housing feet, stick-on <hr/> Power cord ▶ 1 × ▶ Euro version <hr/> CD ROM with user manual <hr/> Installation user manual <hr/> Return note
MACH104-16TX-PoEP-R MACH104-16TX-PoEP+2X-R	Device <hr/> Terminal block ▶ 1 × ▶ 2-pin ▶ for signal contact <hr/> 2 × Brackets with fastening screws (pre-mounted) <hr/> Housing feet, stick-on <hr/> Power cord ▶ 2 × ▶ Euro version <hr/> CD ROM with user manual <hr/> Installation user manual <hr/> Return note
MACH104-16TX-PoEP-E MACH104-16TX-PoEP+2X-E	Device <hr/> Terminal block ▶ 1 × ▶ 2-pin ▶ for signal contact <hr/> 2 × Brackets with fastening screws (pre-mounted) <hr/> Housing feet, stick-on <hr/> Terminal block ▶ 1 × ▶ 3-pin ▶ for supply voltage <hr/> CD ROM with user manual <hr/> Installation user manual <hr/> Return note

■ Accessories

Note: Please note that products recommended as accessories may have characteristics that do not fully correspond to those of the corresponding product. This may limit their possible usage in the overall system.

Name	Order number
Pocket Guide	280 710-851
AutoConfiguration Adapter ACA 21-USB	943 271-001
Terminal cable	943 301-001
2-pin terminal block (50 units)	943 845-010
Bracket for fastening the housing	943 943-001
Long bracket (+ 50 mm) for fastening the housing (additional)	943 943-101
Industrial HiVision Network Management software, operator edition	943 156-xxx
OPC Server software HiOPC	943 055-001
10-Gigabit Ethernet XFP transceiver	Order number
M-XFP-SR/LC	943 917-001
M-XFP-SR/LC EEC	942 054-001
M-XFP-LR/LC	943 919-001
M-XFP-LR/LC EEC	942 055-001
M-XFP-ER/LC	943 920-001
M-XFP-ER/ LC EEC	942 056-001
M-XFP-ZR/LC	943 921-001
Gigabit Ethernet SFP transceiver	Order number
M-SFP-SX/LC	943 014-001
M-SFP-SX/LC EEC	943 896-001
M-SFP-MX/LC	942 035-001
M-SFP-LX/LC	943 015-001
M-SFP-LX/LC EEC	943 897-001
M-SFP-LX+/LC	942 023-001
M-SFP-LX+/ LC EEC	942 024-001
M-SFP-LH/LC	943 042-001
M-SFP-LH/LC EEC	943 898-001
M-SFP-LH+/LC	943 049-001
Fast-Ethernet SFP transceiver	Order number
M-FAST SFP-MM/LC	943 865-001
M-FAST SFP-MM/LC EEC	943 945-001
M-FAST SFP-SM/LC	943 866-001
M-FAST SFP-SM/LC EEC	943 946-001
M-FAST SFP-SM+/LC	943 867-001
M-FAST SFP-SM+/LC EEC	943 947-001
M-FAST SFP-LH/LC	943 868-001
M-FAST SFP-LH/LC EEC	943 948-001
Bidirectional Gigabit Ethernet SFP transceiver	Order number
M-SFP-BIDI Type A LX/LC EEC	943 974-001
M-SFP-BIDI Type B LX/LC EEC	943 974-002
M-SFP-BIDI Type A LH/LC EEC	943 975-001
M-SFP-BIDI Type B LH/LC EEC	943 975-002
M-SFP-BIDI Bundle LX/LC EEC (type A + B)	943 974-101
M-SFP-BIDI Bundle LH/LC EEC (type A + B)	943 975-101

■ Underlying norms and standards

Name	
EN 61000-6-2	Generic norm – immunity in industrial environments
EN 55022	IT equipment – radio interference characteristics
FCC 47 CFR Part 15	Code of Federal Regulations
EN 60950-1	Safety for the installation of IT equipment
IEEE 802.1 D	Switching, GARP, GMRP, Spanning Tree
IEEE 802.1 D-1998	Media access control (MAC) bridges (includes IEEE 802.1p Priority and Dynamic Multicast Filtering, GARP, GMRP)
IEEE 802.1 Q	Tagging
IEEE 802.1 Q-1998	Virtual Bridged Local Area Networks (VLAN Tagging, GVRP)
IEEE 802.1 w.2001	Rapid Reconfiguration
IEEE 802.3-2002	Ethernet

Table 19: List of norms and standards

The device has a certification based on a specific standard only if the certification indicator appears on the housing.

However, with the exception of Germanischer Lloyd, ship certifications are only included in the product information under www.hirschmann.com.

A Further Support

■ Technical Questions

For technical questions, please contact any Hirschmann dealer in your area or Hirschmann directly.

You will find the addresses of our partners on the Internet at <http://www.hirschmann.com>

Contact our support at <https://hirschmann-support.belden.eu.com>

You can contact us

in the EMEA region at

- ▶ Tel.: +49 (0)1805 14-1538
- ▶ E-mail: hac.support@belden.com

in the America region at

- ▶ Tel.: +1 (717) 217-2270
- ▶ E-mail: inet-support.us@belden.com

in the Asia-Pacific region at

- ▶ Tel.: +65 68549860
- ▶ E-mail: inet-ap@belden.com

■ Hirschmann Competence Center

The Hirschmann Competence Center is ahead of its competitors:

- ▶ Consulting incorporates comprehensive technical advice, from system evaluation through network planning to project planning.
- ▶ Training offers you an introduction to the basics, product briefing and user training with certification.

The current training courses to technology and products can be found at <http://www.hicomcenter.com>

- ▶ Support ranges from the first installation through the standby service to maintenance concepts.

With the Hirschmann Competence Center, you have decided against making any compromises. Our client-customized package leaves you free to choose the service components you want to use.

Internet:

<http://www.hicomcenter.com>



HIRSCHMANN

A **BELDEN** BRAND