

measuring wheels
 angle brackets
 clamping claws
 couplings
 spring-loaded bases
 cable sockets

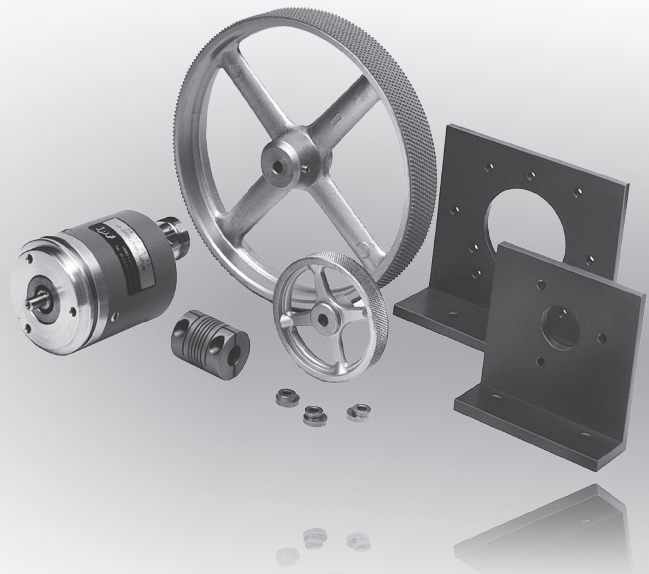

- ✓ suitable for encoders with 6mm shaft
- ✓ also operation in rough conditions
- ✓ angle brackets for mounting the encoders with screws or clamping claws
- ✓ measuring wheels with 200 or 500mm circumference
- ✓ measuring wheels with a choice of materials for the measuring surface offering optimal adaption to the prevailing conditions
- ✓ spring-loaded base for accurate linear measurements

**accessories
 encoder**

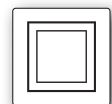
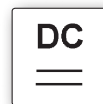
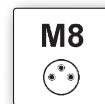

description

Concerning the selection of the measuring wheel, first the type of the object to be measured has to be taken into account in order to then determine the surface and/or the covering of the measuring wheel.

The circumference of the measuring wheel is based on the available space and the size of the counter or encoder.

The smaller the measuring wheel is, the more power has to be applied on the circumference of the measuring wheel and as

such, the risk is greater that a slip will occur and through this, the measured result will turn out to be incorrect.

The width of the measuring wheel also influences the measuring result.

application example

- ▶ linear measurements, angle measurements

article-no.	AV000058	AV000036
circumference	200mm	500mm
external diameter	64mm	159mm
coating profile	rubber with naps	smooth
coating material	nitrile	hytel
wheel material	aluminum	plastic
coating hardness	approx. 55° ±5° shore a	approx. 90° shore a
operating temperature	-10 ... +50°C	-10 ... +70°C
torque range/setscrew	1.5Nm	3.0 Nm
article-no.	AV000034	AV000037
circumference	200mm	500mm
external diameter	63.66 mm	159mm
coating profile	ribbed	rubber with naps
coating material	hytel	nitrile
wheel material	plastic	aluminum
coating hardness	approx. 90° shore a	approx. 55° ±5° shore a
operating temperature	-10 ... +70°C	-10 ... +50°C
torque range/setscrew	1.5Nm	3.0Nm
article-no.	-	AV000043
circumference	-	500mm
external diameter	-	159mm
coating profile	-	ribbed
coating material	-	hytel
wheel material	-	plastic
coating hardness	-	approx. 90° shore a
operating temperature	-	-10 ... +70°C
torque range/setscrew	-	3.0Nm

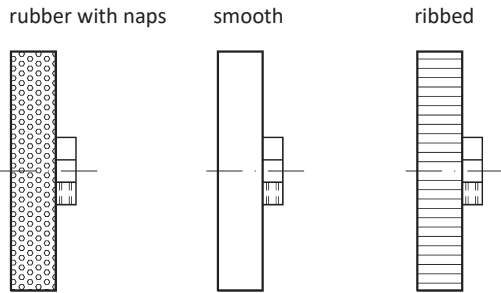

AV000029

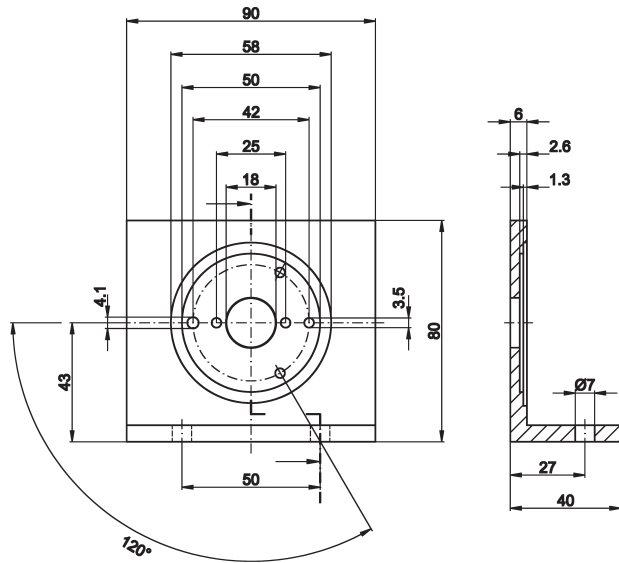

AV000030

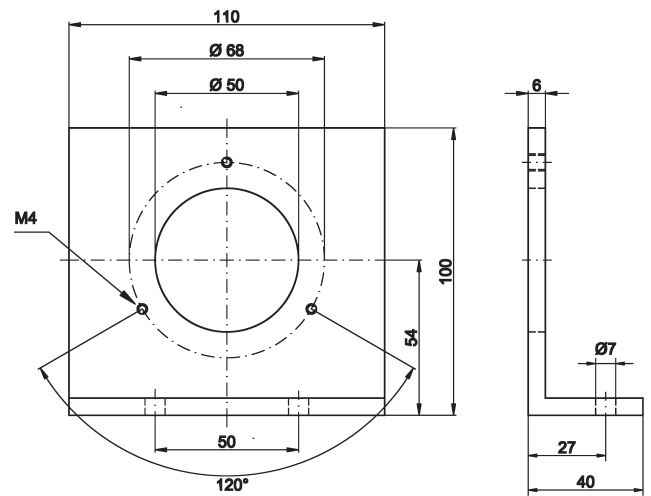

ARTICLE-NO.	DESCRIPTION
AV000029	angle bracket for encoder-mounting with screws

ARTICLE-NO.	DESCRIPTION
AV000030	angle bracket for encoder-mounting with screws

AV000031

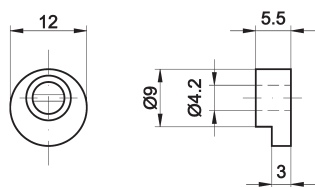

ARTICLE-NO.	DESCRIPTION
AV000031	clamping claw for AV000030

AV000032

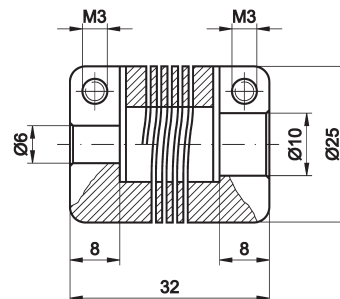

ARTICLE-NO.	DESCRIPTION
AV000032	coupling, Ø25, 32long, 6/10mm shaft

AV000041

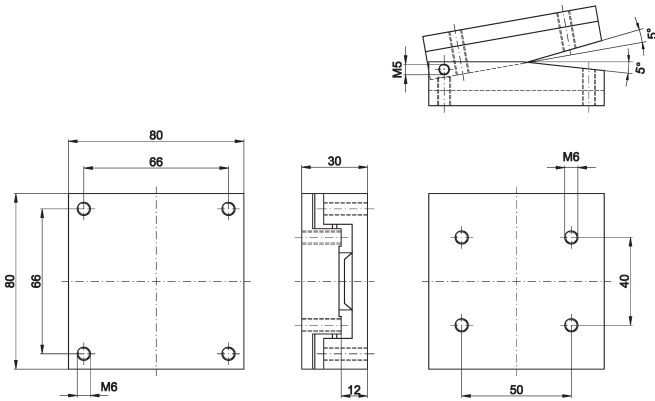

AV000021

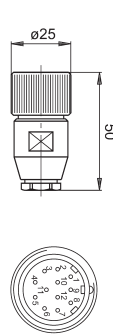

ARTICLE-NO.	DESCRIPTION
-------------	-------------

AV000041	spring-loaded base
----------	--------------------

ARTICLE-NO.	DESCRIPTION
-------------	-------------

AV000021	cable socket straight 12-pin, self ready-made
AV000023	cable socket straight 12-pin, 2m
AV000095	cable socket straight 12-pin, 5m
AV000102	cable socket straight 12-pin, 10m

material surface	recommended measuring wheel surface
------------------	-------------------------------------

plastic, cardboard, wood, textiles	hytrel / ribbed
plastic, varnished surfaces, paper, cardboard, wood, metal, textiles	hytrel / smooth
plastic, metal, textiles	nitrile / rubber with naps

The measuring accuracy of an encoder with measuring wheel depends on the following factors:

- ▶ type of the material to be measured
- ▶ enlacement angle
- ▶ torque of the counter or the encoder
- ▶ transportation speed of the material
- ▶ tensile strength of the material to be measured
- ▶ surface roughness
- ▶ contact pressure of the material to be measured against the measuring wheel
- ▶ elasticity of the material to be measured
- ▶ diameter tolerance of the measuring wheel