

VK30E256

CONNECTION TECHNOLOGY • CABLE SOCKETS /CONNECTORS TWO-SIDED PRE-ASSEMBLED

ipf cable sockets are used primarily for establishing the electrical connection of sensors. Their features are characterized by rugged design, the highest protection classes (IP67 | IP68 | IP69K) and, if desired, with 360° shielding. With the features: bus-ready, suitable for use with drag chains and robots, resistance to oil and chemicals, resistance to welding sparks, their resistance to cleaning agents or high-pressure and steam-jet cleaning, the expanded temperature range of up to +230°C, the rapid interconnection technology and special data transmission properties, the cable sockets meet all requirements in automation technology.



MECHANICAL FEATURES

Approx. outer diameter	6.5 mm
Color of outer sheath	Green
Core identification	Color
Material of outer sheath	PUR (Polyurethane)
Number of cores	4
Perm. ambient temperature of cable, fixed cable	-40 °C ... 75 °C

OTHER FEATURES

Category	5E
Halogen free in acc. with EN 50267-2-2	+

Other

Packaging dimensions	250mm x 25.0mm x 250mm
Shipping weight	0.22kg
Tariff code	85444290

Classification

ipf product group	700
eClass 8.0	27279218
eClass 9.0	27060311
eClass 9.1	27060311
ETIM-5.0	EC001855
ETIM-6.0	EC001855
ETIM-7.0	EC001855

Connection

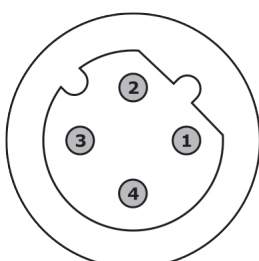

- 1 yellow
- 2 white
- 3 orange
- 4 blue

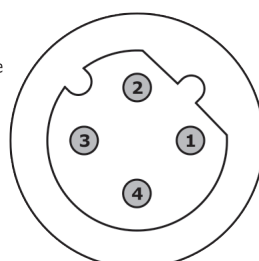

- 1 yellow
- 2 white
- 3 orange
- 4 blue

Dimensional drawing

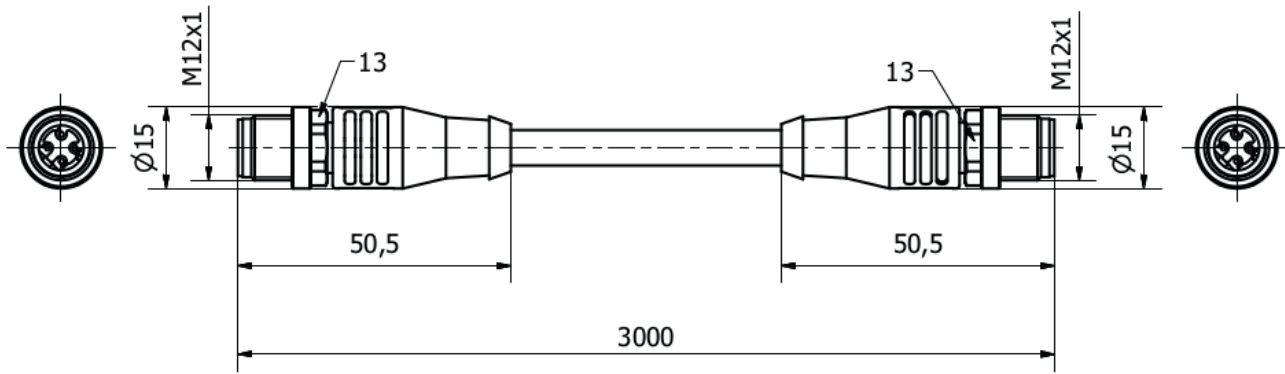

Installation

Disposal



Mounting / installation may only be carried out by a qualified electrician!



Software

Please download the software or driver required for operating your new device on our homepage: www.ipf.de

Safety warnings

Before initial operation, please make sure to follow all safety instructions that may be provided in the product information. Never use these devices in applications where the safety of a person depends on their functionality. LED lighting systems can generate intensive UV radiation, which can damage your eyes in case of improper use. The manufacturer cannot be held responsible for damages that result from improper use or connection.