

dimensions **15.4 x 50 x 50mm**
dif. reflection sensor sensing range **0 up to 250mm**

- ✓ **robust zinc diecast housing**
- ✓ **operating mode and status display by LED**
- ✓ **integrated amplifier, adjustable sensitivity**
- ✓ **digital switching output and analog current output**
- ✓ **high sampling frequency and sensing ranges**
- ✓ **visible red light**
- ✓ **connection with M12-connector or cable**

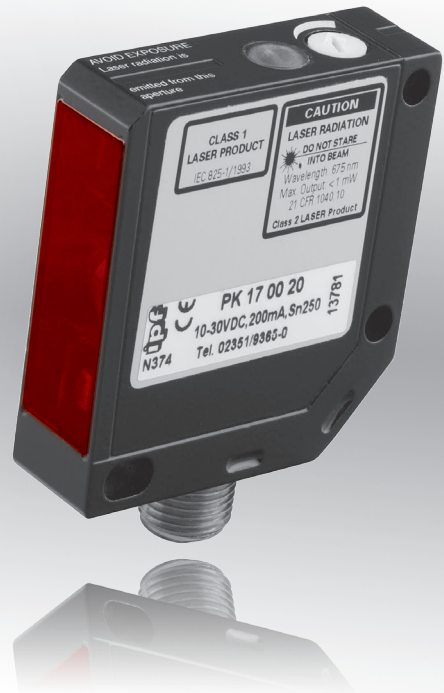

**contrast reader with glass lens
red light class 1 laser**

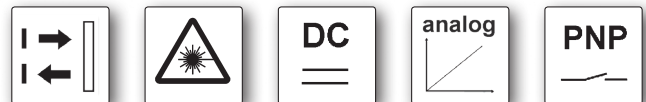

description

These days, optoelectronic sensors are indispensable components in many automated manufacturing processes. **ipf laser contrast readers** are highly modern, optical diffuse reflection sensors, which are capable of recognizing different colored objects or color markers. The only requirement is a contrast divergence against the environment. It is irrelevant whether the contrast divergence shows a tendency towards a light color or a dark one. Due to the very small beam spot, laser contrast diffuse reflection sensors can pick up objects with a high degree of accuracy (to 0.1mm). Sensitivity to outside light sources is negligible. The sensors in this series feature glass lenses in a robust, zinc diecast housing. The distance setting of the sensing devices takes place via a potentiometer. In so doing, protection class IP67 is safeguarded.

The yellow LED display lights up if the output is securely switched. Changes in distance during the reading phase in the operating range 60 and 100mm are non-critical. The analog output (4 ... 20mA) enables measurands to be imported for further evaluation. Deviations from the setpoint can be detected very easily for example using our **ipf** measuring transducer **BA054900** and corrected through the output of a corresponding output signal.

application examples

- ▶ detection of the edges of objects with a high degree of accuracy
- ▶ contact-free detection of positions
- ▶ pulse generator for counting devices
- ▶ recognition of the smallest of objects

article-no.

PK170020

connection

M12-connector

sensing range (operating)

0 ... 250mm

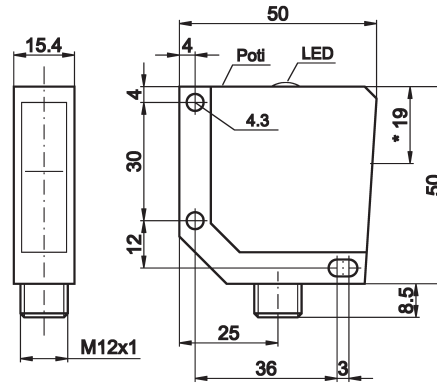

* transmitter axis: 19mm

TECHNICAL DATA

sensing range (limit)	0 ... 250mm
output signal	pnp, light-on mode / 4 ... 20mA
operating voltage	12 ... 30V DC
current consumption (w/o load)	≤ 65mA
output current (max. load)	200mA
voltage drop (max. load)	2.0V DC
transmitting element (pulsed)	laser diode red light
wave length	650nm
laser class	1
distance laser focus	80mm
sampling frequency	5kHz
display (signal)	yellow LED
sensitivity adjustment	potentiometer, 14 revolutions
repeat accuracy	< 0.1mm at laser focus
short-circuit protection	+
reverse polarity protection	+
dimensions	15.4x50x50mm
housing material	zinc diecast
front screen material	glass
operating temperature	-10 ... +50°C
system of protection (EN 60529)	IP67
connection	M12-connector, 4-pin
connection accessories	e.g. VK200325
mounting brackets	AV000084
universal mounting	AY000119

class 1 laser

to DIN EN 60825



connection

connector / cable device

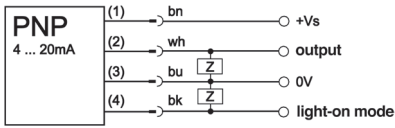

wire colors: bn = brown (1), wh = white (2), bu = blue (3), bk = black (4)

laser beam course

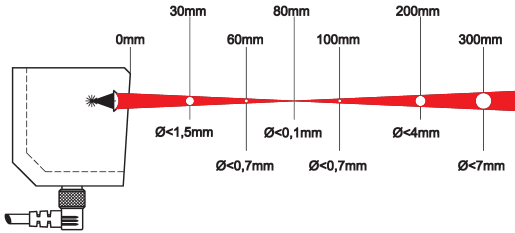

mounting bracket AV000084 made of zinc steel

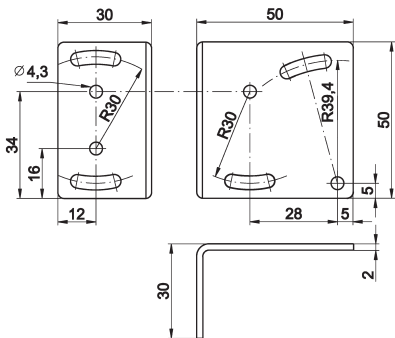

universal mounting AY000094
composed of base module

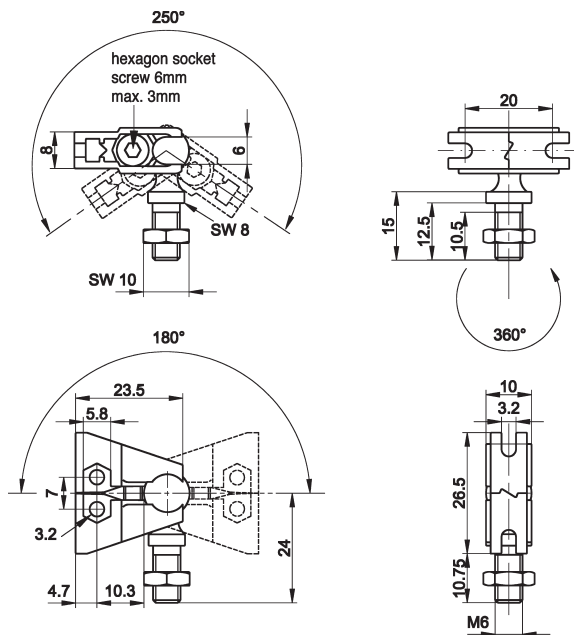

... and fitting panel

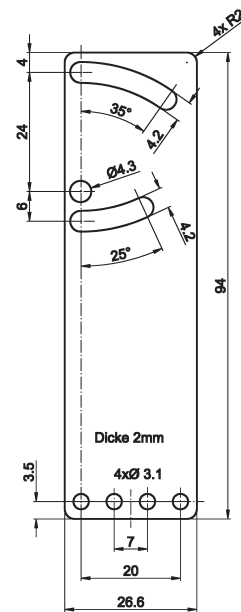

This data sheet contains the standard versions only. Kindly request the availability of other output- and connection functions.

We will be pleased to supply the matching cable socket for your devices with connector. Please refer to the list in catalog chapter "accessories" under "cable sockets **ipf-SENSORFLEX®**" or search our Website for "VK".

Warning: Never use these devices in applications where the safety of a person depends on their functionality.

You also find this data sheet, as well as contact details under www.ipf-electronic.com



NOTES

A large grid area for taking notes, consisting of a 30x30 grid of small squares. The grid is empty and occupies most of the page below the 'NOTES' header.