

## PT650024

### LASER SENSORS • DISTANCE MEASUREMENT

Optical sensors function contactlessly. They detect objects independent of their characteristics (e.g., shape, color, surface structure, material). The basic operating principle is based on the transmission and reception of light. There are three different versions: 1. The through-beam sensor consists of two separate devices, a transmitter and a receiver that are aligned with one another. If the light beam between the two devices is interrupted, the switching output integrated in the receiver changes its status. 2. With the retro-reflective sensor, the transmitter and receiver are located in one device. The emitted light beam is reflected back to the receiver by a reflector that is to be mounted opposite the device. As soon as the light beam is interrupted, the switching output integrated in the device changes its status. 3. With the diffuse reflection sensor, the transmitter and receiver are in one device. The emitted light beam is reflected by the object that is to be detected. As soon as the receiver detects the reflected light, the switching output integrated in the device changes its status.



#### MECHANICAL DATA

|                             |                |
|-----------------------------|----------------|
| Ambient temperature         | 0 °C ... 50 °C |
| Degree of protection (IP)   | IP67           |
| Housing design              | Cuboid         |
| Housing material            | Zinc die-cast  |
| Material of optical surface | Glass          |
| Sensor height               | 65 mm          |
| Sensor length               | 50 mm          |
| Sensor width                | 20.6 mm        |

#### ELECTRICAL DATA

|   |                    |
|---|--------------------|
| Absolute linearity deviation                      | 10 mm              |
| Alarm output                                      | Yes                |
| Decay time  | 10 ms              |
| IO-Link compatible                                | No                 |
| Max. output current                               | 100 mA             |
| Measuring method for optical distance measurement | Triangulation      |
| Measuring range length                            | 200 mm ... 1000 mm |
| No-load current                                   | 100 mA             |
| Number of pins                                    | 5                  |
| Number of switching outputs                       | 1                  |
| Response time                                     | 10 ms              |
| Response/decay time                               | 10 ms              |
| Reverse polarity protection                       | Yes                |
| Scanning function                                 | Light switching    |
| Scanning principle                                | Push button        |
| Short-circuit-proof                               | Yes                |
| Supply voltage                                    | 12 V ... 28 V      |

## ELECTRICAL DATA

|                               |                               |
|-------------------------------|-------------------------------|
| Type of alarm output          | PNP                           |
| Type of analog output         | 0 V ... 10 V / 4 mA ... 20 mA |
| Type of electrical connection | Connector M12                 |
| Type of switching function    | Normally open contact (NO)    |
| Type of switching output      | PNP                           |
| Voltage type                  | DC                            |
| With LED display              | Yes                           |

## OPTICAL DATA

|                           |                        |
|---------------------------|------------------------|
| Geometrical resolution    | 2.5 mm                 |
| Laser protection class    | Class 2                |
| Light beam form           | Point                  |
| Light source              | Laser diode, red light |
| Light spot range          | 12.6 mm <sup>2</sup>   |
| Light spot range          | 12.6 mm <sup>2</sup>   |
| Light spot, laser focus   | 3.14 mm <sup>2</sup>   |
| Resolution                | 2.5 mm                 |
| Small light beam diameter | Yes                    |
| Wavelength of the sensor  | 650 nm                 |

## OTHER DATA

|                              |      |
|------------------------------|------|
| Relative linearity deviation | 10 % |
|------------------------------|------|

## CONNECTION

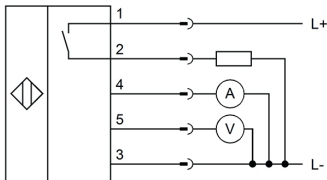

**Colors:** 1 = BN (brown), 2 = WH (white), 3 = BU (blue), 4 = BK (black), 5 = GY (gray)

**Functions:** 1 = L+, 2 = alarm, 3 = L-, 4 = 4-20mA, 5 = 0-10V

## DIMENSIONAL DRAWING

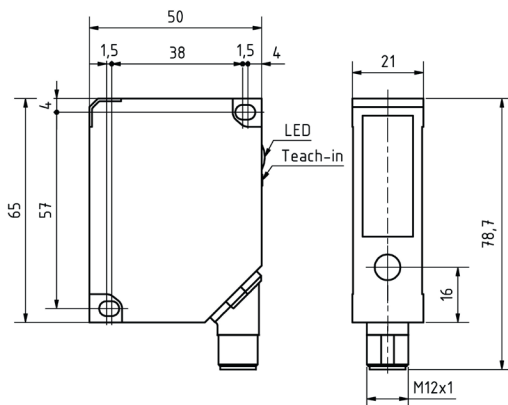

## INSTALLATION

## DISPOSAL



Mounting / Installation may only be carried out by a qualified electrician!



## SAFETY WARNINGS

Before initial operation, please make sure to follow all safety instructions that may be provided in the product information!