

OGSI0309

OPTICAL SENSORS • FORK LIGHT BARRIERS

Special design of through-beam sensor. Transmitter and receiver are located in the fork or angular limbs and are perfectly aligned to each other.

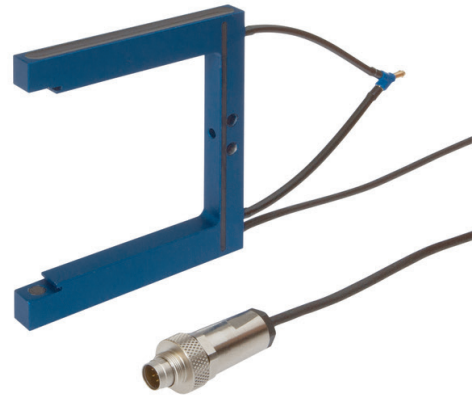

MECHANICAL DATA

Ambient temperature	-20 °C ... 80 °C
Aperture diameter	1.5 mm
Cable length	1 m
Degree of protection (IP)	IP67
Fork depth	60 mm
Fork light barrier design	Furcate
Fork width	60 mm
Heavy soiling	Yes
Housing design	Cuboid
Housing material	Aluminium
Material of cable sheath	Other
Material of optical surface	Glass
Punching tools	Yes
Sensor height	84 mm
Sensor length	74.5 mm
Sensor width	8 mm

ELECTRICAL DATA

Connection to amplifier	Yes
Equipment protection class	Protection class 3
Max. switching distance	60 mm
Number of pins	8
Rated switching distance	60 mm
Relative repeat accuracy	0.5 mm
Repeatability +/-	500 µm
Type of electrical connection	Binder 712
Type of the forked light barrier	Increased soiling reserve
Voltage type	DC

OPTICAL DATA

Laser protection class	None
------------------------	------

OPTICAL DATA

Light beam form	Point
Light source	Infrared light clocked
Light spot	1.5 mm ²
Min. object size	2 mm
Resolution	2000 µm
Wavelength of the sensor	905 nm

OTHER DATA

Feeding technology	Yes
--------------------	-----

CONNECTION

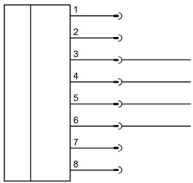

DIMENSIONAL DRAWING

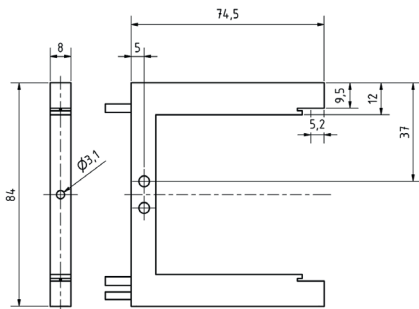

INSTALLATION



Mounting / Installation may only be carried out by a qualified electrician!

DISPOSAL



SAFETY WARNINGS

Before initial operation, please make sure to follow all safety instructions that may be provided in the product information!