

## Table of contents

1. Warranty information
2. Identification
3. Installation
  - 3.1 Mounting the magnetic strip
  - 3.2 Mounting the magnetic sensor
4. Electrical connection
5. Maintenance
6. Trouble shooting
7. Technical data
  - 7.1 Sensors
  - 7.2 Magnetic strip AM000059

## 1. Warranty information

In order to carry out installation correctly, we strongly recommend this document is read very carefully. This will ensure your own safety and the operating reliability of the device.

Your device has been quality controlled, tested and is ready for use. Please observe all warnings and information which are marked either directly on the device or specified in this document.

Warranty can only be claimed for components supplied by ipf electronic gmbh. If the system is used together with other products, there is no warranty for the complete system.

Repairs should be carried out only at our works. For further questions don't hesitate to contact the ipf electronic gmbh.

## 2. Identification

Magnetic strip: The standard magnetic strip with a width of 10mm has article no. AM000059.

Magnetic sensor: The label shows the device type with article number, which clearly identifies the device.

### 3. Installation

For mounting, the degree of protection specified must be observed. If necessary, protect the unit against environmental influences such as sprayed water, dust, knocks, vibrations and extreme temperatures.

#### 3.1 Mounting the magnetic strip

The mounting surface / measuring track must be flat. Buckles or bumps will lead to measuring inaccuracies.

For technical reasons the strip should be approx. 100mm longer than the actual measuring distance.



**Attention!** To guarantee **optimal adhesion** oil, grease dust etc. must be removed by using cleansing agents which evaporate without leaving residues. Suitable cleansing agents are e.g. ketones (acetone) or alcohols; the companies Loctite and 3M can both supply such cleansing liquid. Make sure that the surface to be glued is dry and apply the strip with maximum pressure. Glueing should preferably be undertaken at temperatures between 20°C to 30°C and in dry atmosphere.

**Advice!** When applying long pieces of magnetic strip do not immediately remove the complete protective foil, but rather peel back a short part from the end sufficient to fix the strip. Now align the strip. The protective strip can then be peeled back and put out from the side while pressing the tape firmly onto the mounting surface. A wall paper roller wheel could be used to assist in applying pressure onto the magnetic strip when fixing it in position.

#### Mounting steps (see fig.1)

- Clean mounting surface (1) carefully.
- Remove protective foil (2) from the adhesive side of the magnetic strip (3).
- Stick down the magnetic strip (4).
- Clean surface of magnetic strip carefully.
- Remove protective foil (6) from adhesive tape on the cover strip (5).
- Fix cover strip (both ends should slightly overlap).
- Also fix cover strip's ends to avoid unintentional peeling.

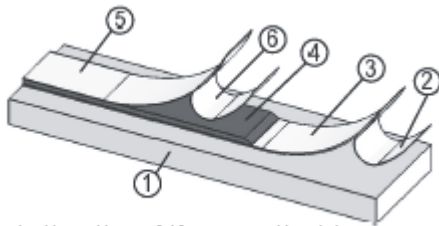

Fig. 1: Mounting of the magnetic strip



**Attention!** Do not expose the system to magnetic fields. Any direct contact of the magnetic strip with magnetic fields (e.g. adhesive magnets or other permanent magnets) is to be avoided. Sensor movements during power loss are not captured by the follower electronics.

### Mounting examples

Mounting with chamfered ends (fig. 2) is not recommended unless the strip is installed in a safe and protected place without environmental influences. In less protected mounting places the strip may peel. There we recommend mounting accord. to fig. 3 and 4.

Mounting in a groove (fig. 5) best protects the magnetic strip. The groove should be deep enough to totally embed the magnetic strip.

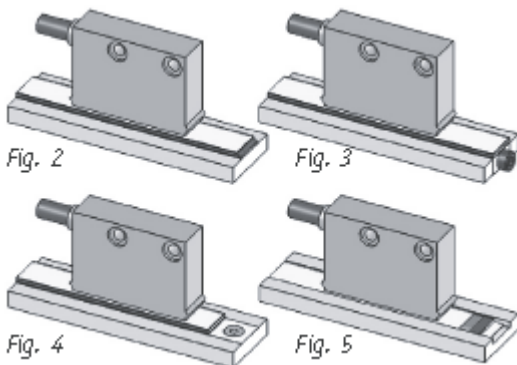

### 3.2 Mounting of the magnetic sensor

The magnetic sensor can be fastened by using two bolts M3 over the  $\varnothing 3.5\text{mm}$  through holes. We recommend to use the enclosed fixing screws and washer springs (fastening torque 0.25Nm).

- Cables should be layed in such a way that there is no danger of damaging. Provide tension relief and drag chain or casing, if necessary.
- Observe the correct alignment with regard to the counting direction (fig. 6). This does not apply if the counting direction can be reversed in the electronic interpretation.
- The tolerance and gap measures must be observed over the whole measuring length.

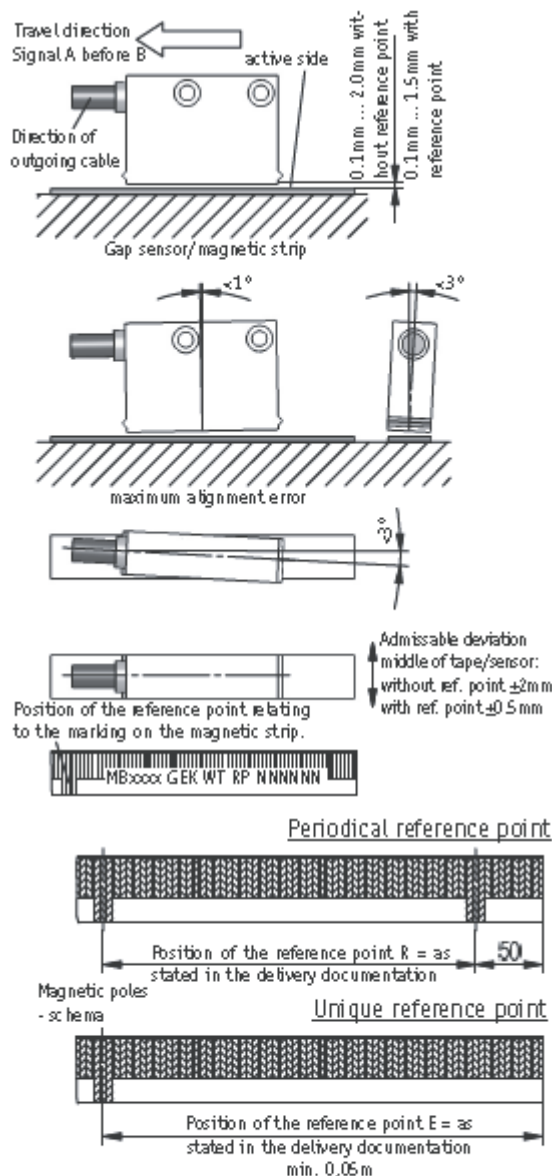

Fig. 6: Definition of the counting direction with magnetic strip and assemblage sensor/magnetic ring, gap measure, tolerances

#### 4. Electrical connection

- Wiring must only be carried out with power off!
- Check all lines and connections before switching on the equipment!



Don't use tin-plated strands in connection with screw terminals!

#### Interference and distortion

All connections are protected against the effects of interference. The location should be selected to ensure that no capacitive or inductive interferences can affect the sensor or the connection lines! Suitable wiring layout and choice of cable can minimise the effects of interference (e.g. interference caused by SMPS, motors, cyclic controls and contactors).

#### Necessary measures

- Only screened cable should be used. Wire cross section is to be at least 0.14mm<sup>2</sup>, max. 0.5mm<sup>2</sup>.
- Wiring to the screen and ground (0V) must be star-shaped and across an extensive area. Ensure that the connection of the screen and earth is made to a large surface area with a sound connection to minimise impedance.
- The system should be positioned well away from cables with interference; if necessary a protective screen or metal housing must be provided. The running of wiring parallel to the mains supply should be avoided.
- Contactor coils must be linked with spark suppression.

#### Supply voltage

The voltages depend on the sensor designs; they are to be taken from the delivery documentation and the identification plate (e.g. UB=24V DC ±20%).

#### 5. Maintenance

We recommend cleaning the magnetic strip's surface from time to time with a soft cloth.

## 6. Trouble shooting

Below are some typical errors which may occur during installation and operation:

- Magnetic strip incorrectly mounted (active surface must be mounted towards the sensor) (see chapter 3.1)
- Use of foreign protective strip. Must always be non-magnetic.
- Sensor not or incorrectly connected (pin connection, see chapter 7).
- Tolerance for the gap between magnetic sensor and magnetic strip not observed over the **total** travel distance. Sensor touches strip (see fig. 6)
- Cable squeezed / interrupted / cut by sharp edges.
- Sensor's active side not mounted towards the magnetic strip (see fig. 6). The active side is marked by the label "Bandseite" (strip side).
- Sensor has not been aligned according to fig. 6.

## 7. Technical data and list of articles

### 7.1 Sensors

	MW110400	MW110405 MW110406*	MW110410 MW110411*	MW110430 MW110431*	MW110435
operating voltage	24V DC ± 20%	5V DC ± 5%	24V DC ± 20%		5V DC ± 5%
current consumption (w/o load)	70mA				
type of output	Push-Pull	Line Driver	Push-Pull		Line Driver
output signals	A, /A, B, /B		A, /A, B, /B, I, /I	A, /A, B, /B	
max. linear traverse speed	6.9m/s			1.7m/s	
resolution	0.01mm				
system accuracy	±(0.025 + 0.01 x L)mm			(L in m)	
repeat accuracy	± 1 increment				
pulse gap	1µs			4µs	
distance sensor - strip	0.1 ... 2mm	0.1 ... 1.5mm		0.1 ... 2mm	
ambient temperature	-10 ... +70°C				
protection class	IP67 (EN 60529)				
housing material	plastic black				
electrical connection	2m PUR-cable				
notes	for SPS-counter cards or external counters with min. 250kHz frequency of count			for external counters with min. 100kHz frequency of count	

\* electrical connection 5m PUR-cable

**special device MW11C580:** technical data see MW110410  
 electrical connection 15m PUR-cable  
 for magnetic strip with one-time reference point

## pin configuration

## dimensional drawing

wire allocation	color
+UB	brown
GND A	black
A	red
inverse	yellow
B	orange
B	green
inverse I	blue*
I inverse	violet*

\* only MW11041x and MW11C580

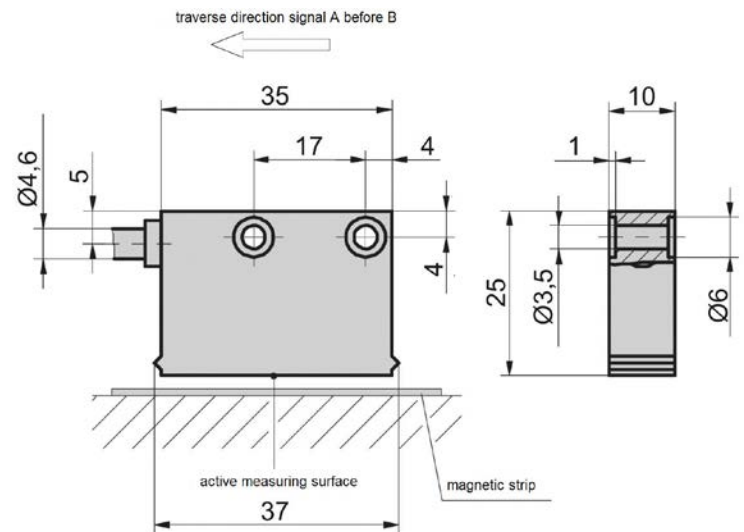

## 7.2 Magnetic strip AM000059

pole length	5mm
strip length	any
thickness	10mm
temperature (operating)	1.4mm without cover strip
temperature (storage)	-20 ... +70 °C
temperature coefficient	-40 ... +70 °C
humidity	$(11 \pm 1) \times 10^{-6} / K$

mounting 100 % rF, condensation permitted, adhesive bond, pre-mounted double-sided adhesive tape

material cover strip stainless steel

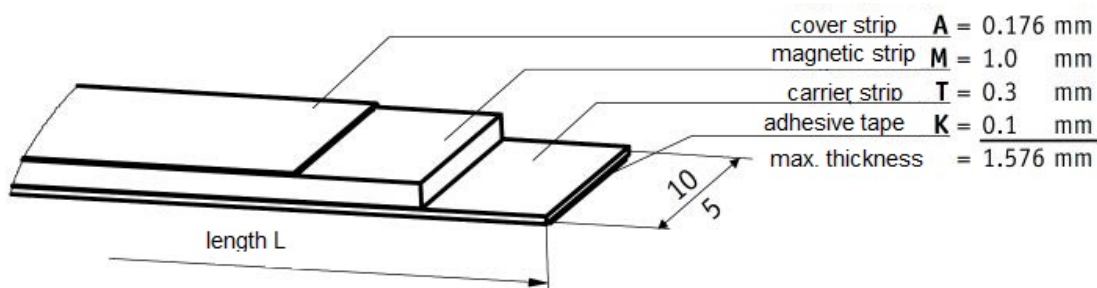

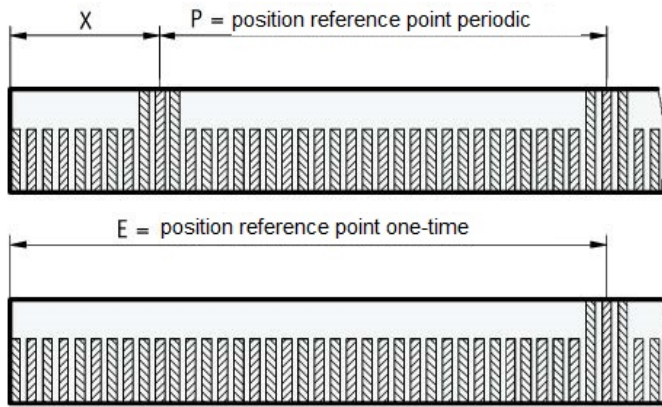

reference points (in mm)

<b>X</b>	0.05
<b>P</b>	0.2, 0.5
<b>E</b>	0.05, 0.1, 0.2, 0.5, 0.9, 1.3, 2.0

**Special version AM98C581:** length 6m  
one-time reference point P: 0.1m

**Warning:** Never use these devices in applications where the safety of a person depends on their functionality.