

OC538D24

CAMERA SENSORS • CAMERA SENSORS

Camera sensors are used to simultaneously check various properties of objects (e.g., completeness, dimensional accuracy, position, damages, labeling). This takes place independent of the component position virtually in real time. Camera sensors are image processing systems that combine image sensor and image processing computer with image processing software in a metal housing. Depending on the version, lens and illumination unit are also integrated in the housing or must be additionally mounted. The camera sensors are set using an intuitive software program. On the device, object-specific check programs can be stored that contain the respective feature checks. These programs can be activated depending on the object that is to be inspected. The rugged housing design makes possible use under harsh environmental conditions.



MECHANICAL DATA

Ambient temperature (MAX)	50 °C
Ambient temperature (MIN)	5 °C
Degree of protection (IP)	IP67
Housing coating	With powder coating
Housing material	Aluminium
Material of optical surface	PMMA
Sensor height	113 mm
Sensor length	38 mm
Sensor width	53 mm

ELECTRICAL DATA

Error image memory	32
Feature comparison, color arrangement	No
Feature comparison, color determination	No
For interchangeable lens (C-mount)	No
Input voltage at DC (MAX)	30 V
Input voltage at DC (MIN)	8 V
Integrated flash controller for external illumination	No
Max. output current	100 mA
Measuring time for high speed	100 fps
No-load current	208 mA
Number of digital inputs	5
Number of digital outputs	5
Number of pins	12
Number of pins of the communication interface	4
Number of switching outputs	5
Operating voltage (MAX)	30 V
Operating voltage (MIN)	18 V
Power consumption	5 W

ELECTRICAL DATA

Property picture system	Infrared
QR code and barcode identification	No
Reverse polarity protection	Yes
Setting procedure	Application software
Short-circuit-proof	Yes
Type of communication interface	Connector M12
Type of electrical connection	M12-connector
Type of plug-in contact, communication interface	Female (socket)
Type of switching function	Programmable/configurable
Type of switching output	PNP
With communication interface, Ethernet	Yes
With communication interface, RS-232	No
With communication interface, RS-485	No
With Ethernet/IP	Yes
With Profinet	Yes
With RS485	No

OPTICAL DATA

Dimensional accuracy	Yes
Feature comparison, area size	Yes
Feature comparison, brightness	Yes
Feature comparison, contour comparison	Yes
Feature comparison, contrast	Yes
Feature comparison, count areas	Yes
Feature comparison, count contour points	Yes
Feature comparison, pattern comparison	Yes
Focal distance	12mm
Geometry - angle	Yes
Geometry - circle	Yes
Geometry - count edges	Yes
Geometry - distance	Yes
Geometry - point position	Yes
Geometry of edge contour	No
Image recorder	CMOS(1/3")
Light source	Infrared light
Measuring time for high resolution	50 fps
Minimum distance	50 mm
Object evaluation regardless of position	Yes
Part location on circle	Yes
Part location on contours	Yes
Part location on edges	Yes
Part location on text line	Yes
Pick and place	Yes
Resolution	752x480
Testing and sorting	Yes
Text identification (OCR)	No

OTHER DATA

Air humidity	0 ... 90% noncondensing
Risk groups	0
Shock resistance in acc. with EN 60068-2-27	Yes
Vibration resistance in acc. with IEC 60068-2-6 / IEC 60068-2-64	Yes

CONNECTION

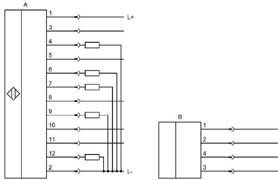

Colors: A: 1 = BN (brown), 2 = BU (blue), 3 = WH (white), 4 = GN (green), 5 = PK (pink), 6 = YE (yellow), 7 = BK (black), 8 = GY (gray), 9 = RD (red), 10 = VT (violet), 11 = GY/PK (gray/pink), 12 = RD/BU (red/blue)

B: 1 = BN (brown), 2 = WH (white), 3 = BU (blue), 4 = BK (black)
Functions: A: 1 = L+, 2 = L-, 3 = trigger, 4 = out 1, 5 = In 2, 6 = out 2, 7 = out 3, 8 = In 3, 9 = out 4/ RS485, 10 = In 4, 11 = in 5, 12 = out 5/RS485

B: 1 = TD+, 2 = TD-, 3 = RX+, 4 = RX-

DIMENSIONAL DRAWING

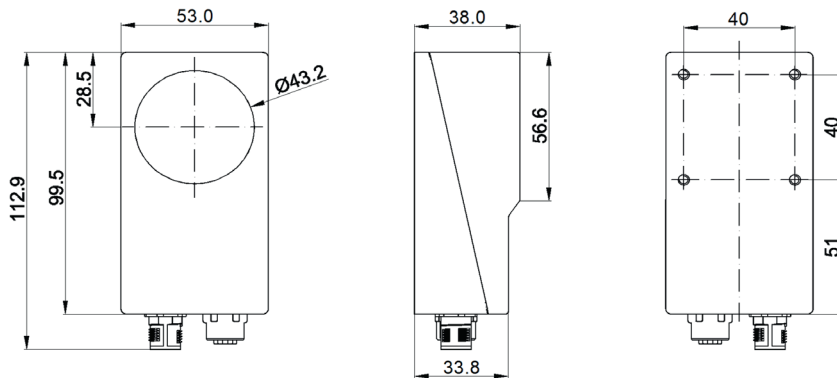

INSTALLATION



Mounting / Installation may only be carried out by a qualified electrician!

DISPOSAL



SAFETY WARNINGS

Before initial operation, please make sure to follow all safety instructions that may be provided in the product information!

Never use these devices in applications where the safety of a person depends on their functionality.