

**AO000505**

**ACCESSORIES • LENSES**



**MECHANICAL DATA**

Accessories for	Camera illumination
Filter thread size, metric	27
Housing material	Aluminium
Lamp thread size, metric (internal)	40.5
Pitch of filter thread	0.5 mm
Pitch of lamp thread (internal)	0.5 mm
With C-mount thread	No

**OPTICAL DATA**

Motor zoom	No
------------	----

**DIMENSIONAL DRAWING**

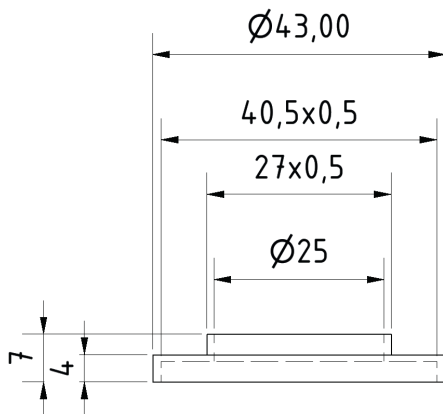

**INSTALLATION**

**DISPOSAL**



Mounting / Installation may only be carried out by a qualified electrician!



## SAFETY WARNINGS

Before initial operation, please make sure to follow all safety instructions that may be provided in the product information!

Never use these devices in applications where the safety of a person depends on their functionality.