

NR700201

POWER SUPPLY UNITS • POWER SUPPLY UNITS

Pulsed power supplies are used to supply electrical systems or system parts with a stabilized DC voltage. Due to the lower copper losses, pulsed power supplies in the lower power range are considerably more efficient than power transformers. Furthermore, they are more compact and are lighter weight than conventional, linear regulated power supplies, which contain a heavy transformer with iron core and cause additional losses in the linear regulator.



MECHANICAL DATA

Ambient temperature (MAX)	60 °C
Degree of protection (IP)	IP20
Depth	60 mm
Direct mounting possible	Yes
Height	45 mm
Housing material	Plastic
Rail mounting possible	Yes
Suitable for serial installation	Yes
Wall mounting possible	No
Width	90 mm

ELECTRICAL DATA

1. output voltage (MAX)	30 V
1. output voltage (MIN)	5 V
Max. input current	0.4 A
Max. output current 1	2 A
Output voltage	24 V
Output voltage, regulated	Yes
Power output	47 W
Rated supply voltage at AC 50 Hz (MAX)	24 V
Rated supply voltage at AC 50 Hz (MIN)	24 V
Residual ripple	0.2 %
Secondary voltage, adjustable	Yes
Suitable for safety functions	No
Type of electrical connection	Screw connection
Voltage type of supply voltage	AC
With LED display	Yes

OTHER DATA

Stabilized	Yes
------------	-----

DIMENSIONAL DRAWING

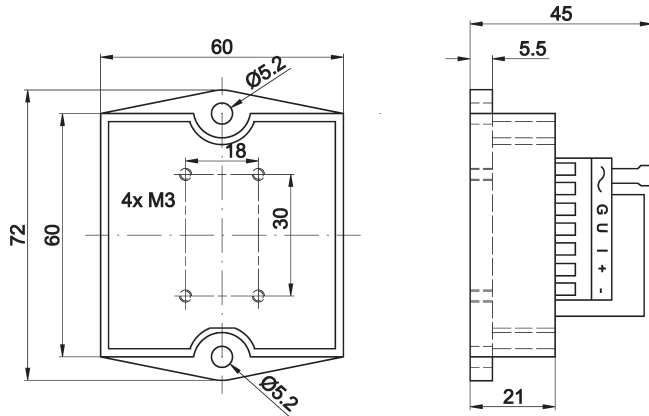

INSTALLATION



Mounting / Installation may only be carried out by a qualified electrician!

DISPOSAL



SAFETY WARNINGS

Before initial operation, please make sure to follow all safety instructions that may be provided in the product information!

Never use these devices in applications where the safety of a person depends on their functionality.