

PY930908

SAFETY SYSTEMS • LASER CURTAINS

Radar sensors are used primarily as signal transducers for controlling automatic doors and gates. They detect the movement of persons and/or industrial trucks and, at the same time, are insensitive to soiling. Objects can be detected depending on their movement direction in order to optimize the opening cycles of the gates. In doing so, it is possible to mask out people so that the sensor responds only when vehicles approach. Furthermore, it is possible to eliminate interference caused by moving objects within the detection range of the sensor. Systems that are also equipped with presence detection monitor the area in front of a gate in order to prevent the gate leaf from coming into contact with vehicles or objects.



MECHANICAL DATA

Ambient temperature (MAX)	60 °C
Ambient temperature (MIN)	-30 °C
Cable length	10 m
Color	Black
Housing material	Polycarbonate
Inclination angle (MAX)	3 °
Inclination angle (MIN)	-3 °
Material	Plastic
Mounting height	10 m
Mounting method	Surface mounted (plaster)
Number of wires	10
Optimum mounting height	10 m
Sensor height	70 mm
Sensor length	93 mm
Sensor width	125 mm
Suitable for degree of protection (IP)	IP65
Version	Motion sensor/presence sensor

ELECTRICAL DATA

For control of industrial doors and gates	Yes
Max. output current	80 mA
Number of switching outputs	2
Operating voltage (MAX)	35 V
Operating voltage (MIN)	10 V
Power consumption	5 W
Reaction time	80 ms
Response luminosity, adjustable	No
Response time	20 ms
Setting procedure	Parameterization
Setting via remote control	Yes
Staircase monitoring	No

ELECTRICAL DATA

Suitable for wireless transmission	No
Switching voltage	24 V
Type of electrical connection	Cable
Type of switching function	Normally closed contact/normally open contact
Type of switching output	Relay contact
Voltage type	DC
With LED display	Yes

OPTICAL DATA

Detection angle horizontal (MAX)	3 °
Detection angle horizontal (MIN)	-3 °
Detection range laser height	25 m
Detection range laser width	25 m
Light source	Laser diode, red light
Max. front range	25 m
Max. side range	25 m
Wavelength of the sensor	905 nm

CONNECTION

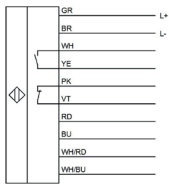

Colors: GN (green), BN (brown), WH (white), YE (yellow), PK (pink), VT (violet), RD (red), BU (blue), WH/RD (white/red), WH/BU (white/blue)

Functions: GN = L+, BN = L-, WH = relay 1, YE = relay 1, PK = relay 2, VT = relay 2, RD 0 test +, BU = test-, WH/RD = teach-in, WH/BU = teach-in

DIMENSIONAL DRAWING

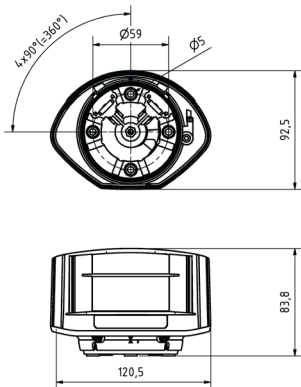

INSTALLATION

DISPOSAL



Mounting / Installation may only be carried out by a qualified electrician!



SAFETY WARNINGS

Before initial operation, please make sure to follow all safety instructions that may be provided in the product information!

Never use these devices in applications where the safety of a person depends on their functionality.