

AY000161
ACCESSORIES • MOUNTING

accessories sensor, Foot clamp holder, Ø38mm 25high, Aluminum



MECHANICAL FEATURES

Diameter	38 mm
Height	25 mm
Housing material	Aluminum
Material	Aluminum
Type of mechanical accessories	Foot clamp holder

ELECTRICAL FEATURES

Internal hole diameter	12 mm
------------------------	-------

OTHER FEATURES

Current plunger	-
-----------------	---

Other

Packaging dimensions	100mm x 25.0mm x 130mm
Shipping weight	0.04kg
Tariff code	76169990

Classification

ipf product group	900
eClass 8.0	27279202
eClass 9.0	27273701
eClass 9.1	27273701
ETIM-5.0	EC002024
ETIM-6.0	EC002024
ETIM-7.0	EC002024

Connection

Dimensional drawing

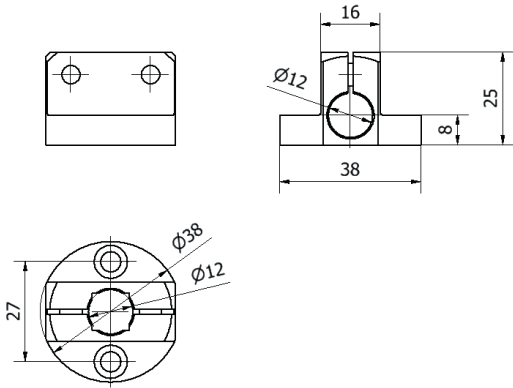

Installation



Mounting / installation may only be carried out by a qualified electrician!

Disposal



Safety warnings

Before initial operation, please make sure to follow all safety instructions that may be provided in the product information. Never use these devices in applications where the safety of a person depends on their functionality. LED lighting systems can generate intensive UV radiation, which can damage your eyes in case of improper use. The manufacturer cannot be held responsible for damages that result from improper use or connection.